

○ Standard configuration

Engine

- Isolated mounted engine
- Dynamic hunting mode control
- Radiator (with full protective screening)
- 24V/6.5kW starter motor
- 50A alternator
- Dry type dual-element air filter
- Engine oil filter
- Three-stage fuel oil filter
- Engine oil cooler
- Radiator auxiliary water tank
- Fan aerofoil
- Automatic idling system

Hydraulic system

- Operating mode selector switch
- Control valve with main overflow valve
- Control valve with spare oil port
- Oil suction filter
- Return oil filter
- Pilot filter
- Oil drain filter

Slewing platform of superstructure

- Fuel oil level sensor
- Hydraulic oil level gauge
- Tool kit
- Slewing parking brake
- Rearview mirror (right)
- Rearview camera *
- Cab alarm lamp *

Cab

- Ultra-silence frame cab
- Reinforced light-color glass window
- Silicone oil rubber damper
- Openable top/front wall upper window and left side window
- Emergency exit on rear window
- Wiper (with washer)
- Multidirectional adjustable seat
- AM-FM radio (with digital clock)
- Foot rest and floor mat
- Loudspeaker and rearview mirror
- Seat belt and fire extinguisher
- Cup holder and compartment lamp
- Ashtray and escape hammer
- Storage box and sundries bag
- Pilot controlled cut-off lever
- Fully-automatic air conditioner
- Front protective screening

Front-end working device

- Flange pin
- Bucket clearance adjuster
- Welded connecting rod
- Central lubricating system
- All bucket pins are equipped with dustproof seal ring
- Reinforced all-welded box-type boom
- Reinforced all-welded box-type bucket rod
- Anti-collision guard plate

Instruments of monitoring system

- Global positioning system (GPS)
- 7" colored display screen
- EEVIA system
- Hour meter and fuel tank oil level gauge
- Engine coolant temperature gauge

Traveling body of undercarriage

- Traveling parking brake
- Traveling motor guard plate
- H-shaped track guide mechanism
- Hydraulic tensioning device of tracks
- Bolted driving wheel
- Thrust wheel and carrier wheel
- Reinforced chain trail with pin seal
- 600mm triple track shoes
- Reinforced side pedal
- Bottom cover plate

Alarm system

- Controller failure
- Pump pressure abnormal
- Pilot pressure of various movements abnormal
- Power supply voltage abnormal
- Starter motor relay abnormal
- Hydraulic oil temperature abnormal
- Engine oil pressure insufficient or engine coolant temperature too high
- Fuel volume insufficient
- Return oil filter restriction alarm
- Engine failure alarm
- Fuel oil filter water level alarm

Others

- High-capacity storage battery
- Lockable engine hood
- Lockable fuel filler cap
- Anti-slip sticker for armrest and sidewalk
- Traveling direction sign on traveling carriage
- Manual grease gun

* indicates optional configuration



Shanghai SANY Heavy Machinery Co., Ltd.

www.sany.com.cn

Shanghai SANY Heavy Machinery Industrial Park, Ping'an Town, Fengxian District, Shanghai City, China

Note

This is a sample and is only for reference. All configuration shall be subject to the contract or material object, and may be changed without further notice. All Rights Reserved! No contents in the sample shall be duplicated or copied for any purposes without written approval of SANY Heavy Machinery.

© Printed in China
No.: ZJSYX0604CH (March 2016)



SY245H

Hydraulic excavator

Brand new change

MOST CLASSIC MODEL
Strive only for Classic Product

- **Rated power**
147kW/2100rpm
- **Total weight**
25500kg
- **Bucket capacity**
1.3m³



SY245H



Strive only for Classic Product

New-generation Super Hydraulic Excavator for Mining



Selling Points

SY245H is a brand new 24T-level hydraulic excavator product for mining produced by SANY Heavy Machinery. It is designed particularly for heavy-duty conditions of medium/small-sized mines and targets to improve customer's investment return. As compared with competitor brands, it has five major selling points including "super long service life, super excellent performance, super low maintenance cost, super high adaptability to working conditions and super easy management".



Super long service life



Excellent performance



Super low maintenance cost



Super easy management



Super high adaptability to working conditions

Super long service life

Through the accumulation over 15 years, service life of SY245H exceeds 15,000h under mining conditions, is 20% higher than general excavator and surpasses foreign brands with the help of initiative "three-dimensional" design test system for large-scale excavator.

Five major structural members

As compared the product of previous generation, the service life of key structural members like boom, bucket rod, bucket, platform and undercarriage etc. is doubled

Hydraulic system

Delivery cleanliness of hydraulic system reaches NAS7 and is not only higher than competitor brands but also higher than industrial standard

Core parts

Core parts like main pump, main valve, oil cylinder and retarder etc. guarantee super long life



Key structural members

With most advanced international methods including optimization design of structural members, stress test, research of welds and plates, endurance test, 100% UT detection for key components and fatigue test for two axles, the service life of key structural members is improved comprehensively. Failure rate in 15000H only is 5%.



The boom adopts box-type structure with higher strength and is made of high-strength steel plates through advanced welding and molding process. The service life under mining conditions is four times of general boom.



Bucket rod adopts bottom plate reinforcing bars and forging front support etc. As compared with competitor brands, the stress on main loading point is 30% lower, and the service life is 30% higher under mining conditions.



In allusion to the positions with concentrated stress such as oil cylinder connections and boom root etc., special welding process and protection structure are used. The stress on loading point is 20% lower than the competitor.



Dedicated heavy-duty four-wheel & one-belt is used, and the service life is doubled. The guard plate is upgraded to multi-stage guard plate so that the service life is improved by 100%.

Core parts

Relying on the only endurance test system for excavator parts in China, and through joint research with world famous research institutions, the research on service life of the parts is carried out for improving the service life of core parts comprehensively. The service life of components including pump, valve, oil cylinder, retarder, fuel tank and cab etc. is doubled.

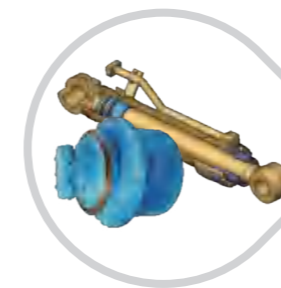

Hydraulic components like oil cylinder and retarder etc. must be subjected to impulse test according to the requirements higher than industrial standard. They can be put into operation only after reaching the requirements. Through this process, the service life of the components is 30% higher than that of general brands.

Oil cylinder impulse test bed

Pump- valve test bed

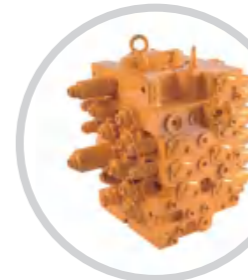

With pump-valve endurance test bed, the service life of main pump and main valve are tested and analyzed. In combination with research achievements of long-life parts of the customer, the service life of the pumps and the valves is improved by 1 time.

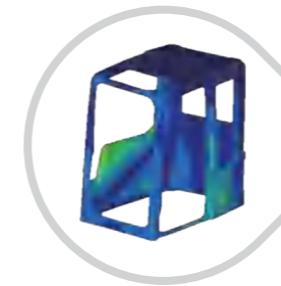

With vibration test bench and test bed, fuel tank and the cab has been tested by over hundreds of thousands of times on aspect of the vibration to improve the service life of the component by 50%.

Vibration test bench and test bed

Hydraulic system

By monitoring hydraulic oil upon delivery and in after-sales stage, ensure the cleanliness of hydraulic oil to be within the scope of NAS7 in full life cycle of the product. It is 2 levels higher than industrial standard and surpasses the competitor by 30%.

As shown in the table below, the cleanliness of hydraulic oil used in the machine of SANY has been stabilized below level 9 since June 2014.

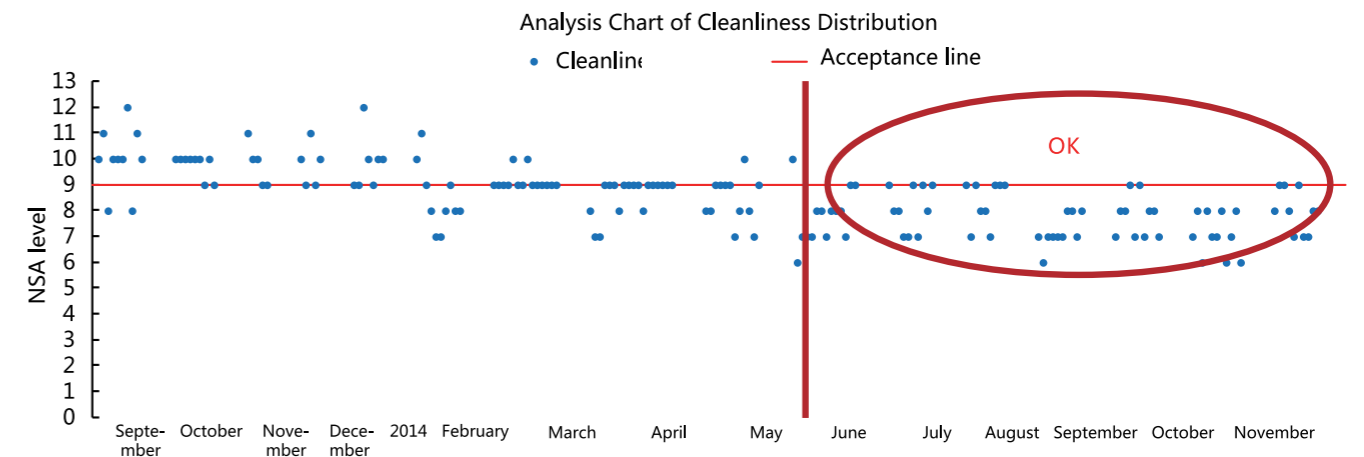

Super excellent performance

Super low maintenance cost

Efficient and low consumption

With "positive flow" system and "DOMCS" dynamic hunting intelligent matching control system developed independently by SANY, the efficiency and fuel consumption surpass competitor brands. The efficiency is 8% higher and the fuel consumption is 10% lower. The engine is exclusively for SANY, with strong power and high reliability. Thus, it can ensure the continuous operating stability in severe environment. As compared with foreign brands, it not only saves fuel but also works faster!

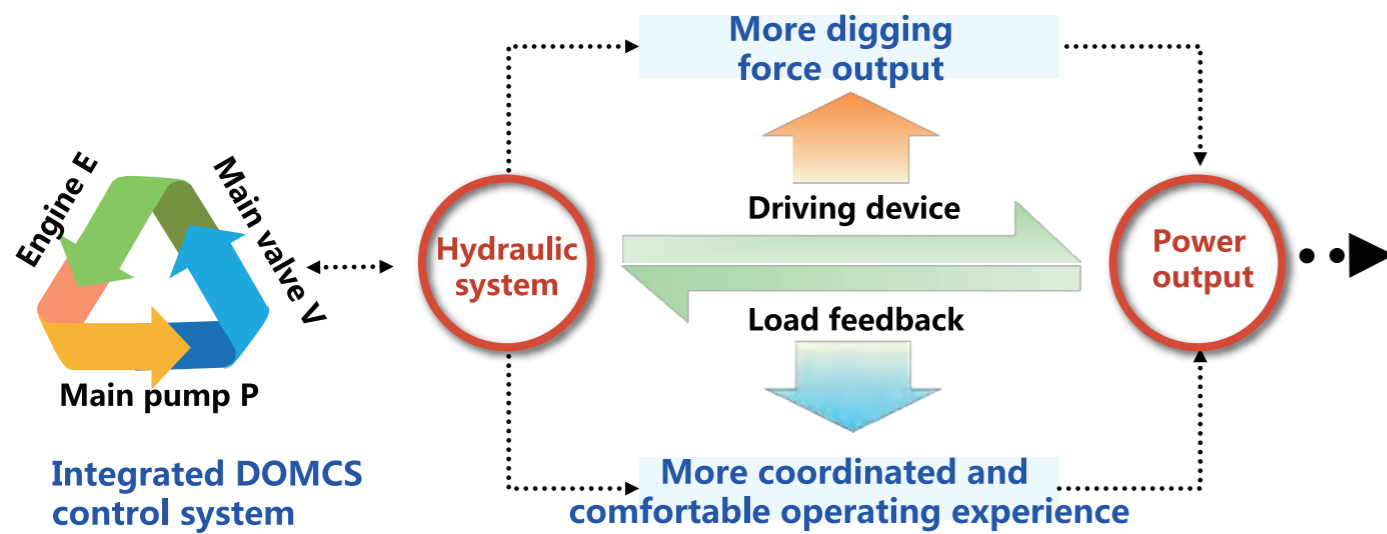

Smooth controllability

With special handle, optimized valve core structure, regenerating channel and added intelligent interflow control etc. The pressure loss is reduced, operation coordination is improved and the equipment can be operated easily and smoothly.



Super lower maintenance cost

SANY is developing long-life engine oil, diesel oil filter and hydraulic oil jointly with professional manufacturers. Through two years' market verification, maintenance cost of the product is reduced by 50%, and maintenance interval is extended by 1 time.

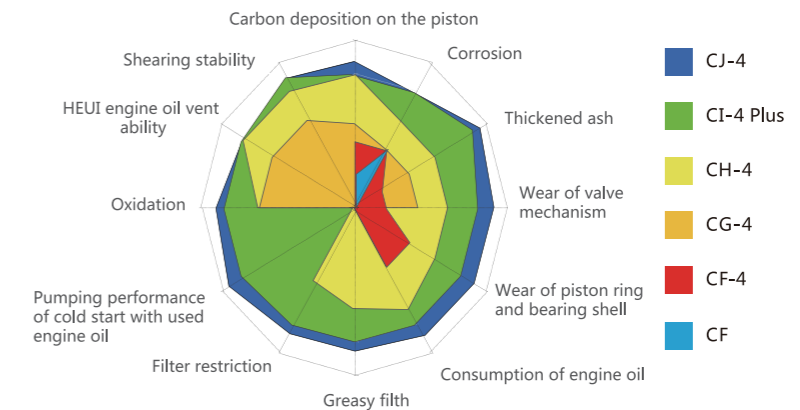

Maintenance cost

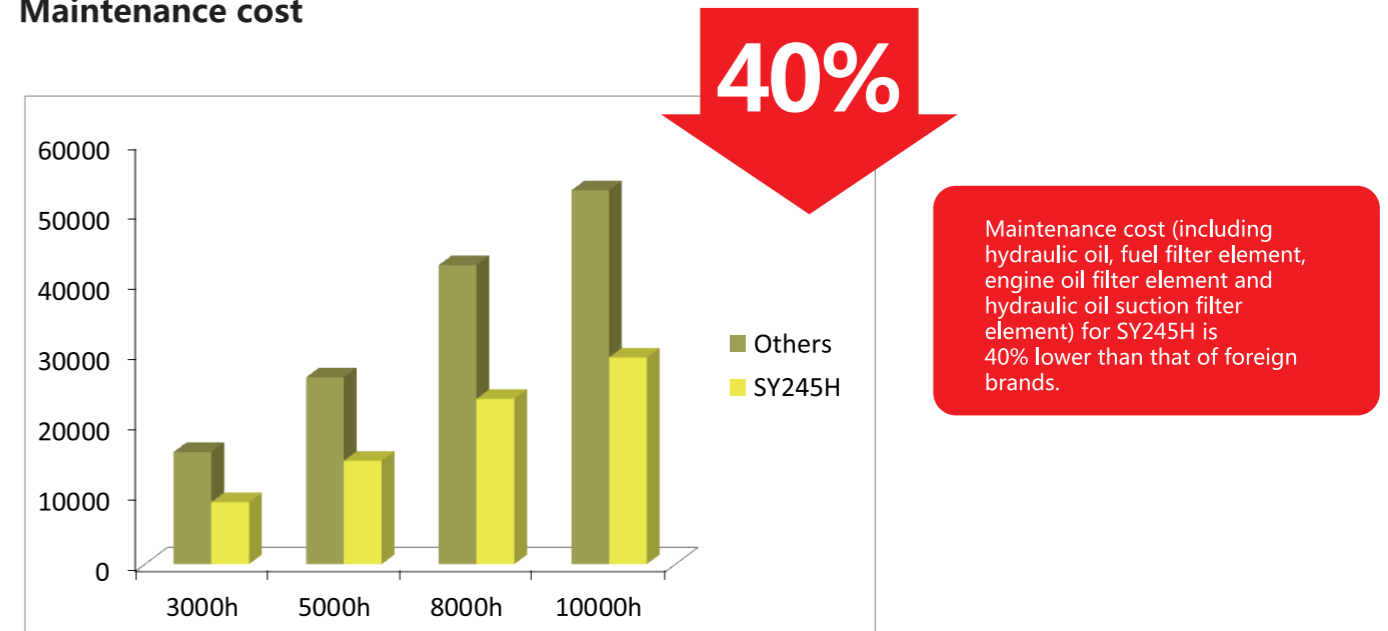

Super easy management

Super easy management

Replacement space for maintainable parts is increased and the parts are designed in allusion to severe mining conditions for convenient maintenance. It is thus easier and simpler to manage the equipment. It is equipped with four-dimensional construction management system developed independently by SANY.



Filter position is easy for maintenance

Fuel oil fine filter and engine oil filter element are overhead. They can be replaced only by opening the engine hood.

Easy to clean the radiator

The radiator is protected with external protective screening which is fastened with butterfly nuts. The dirt is blocked out by the protective screening. It is only necessary to remove the protective screening when cleaning.

Pump chamber

Pump chamber volume is increased by 30%. Operating space for filter replacement is increased by 20%

**30%/
20%**

Maintenance convenience

In allusion severe working conditions of the mine, the design of maintenance convenience of the maintainable parts is improved. "Big space, Easy to operate". Maintenance space for various maintainable parts increases by 20%-30% and makes the operation easier!



Replace air filter element

Easy to replace air filter element



Replace diesel oil filter element

Easy to replace diesel oil filter element



Inspect the situation of engine oil



Pump oil by one push after engine goes off abnormally

Easy to inspect engine oil; pump oil by one push after engine goes off abnormally



Engine compartment

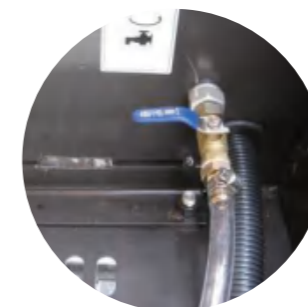

Check valve

Engine compartment volume is increased by 20%, and water drain valve and diesel oil check valve are added

Super adaptability

Based on design concept of "one machine for multiple purposes", new appearance and new coating are used to improve the safety and heat dissipation capability. Standard connectors are developed in allusion to mining conditions and make the refitting convenient.

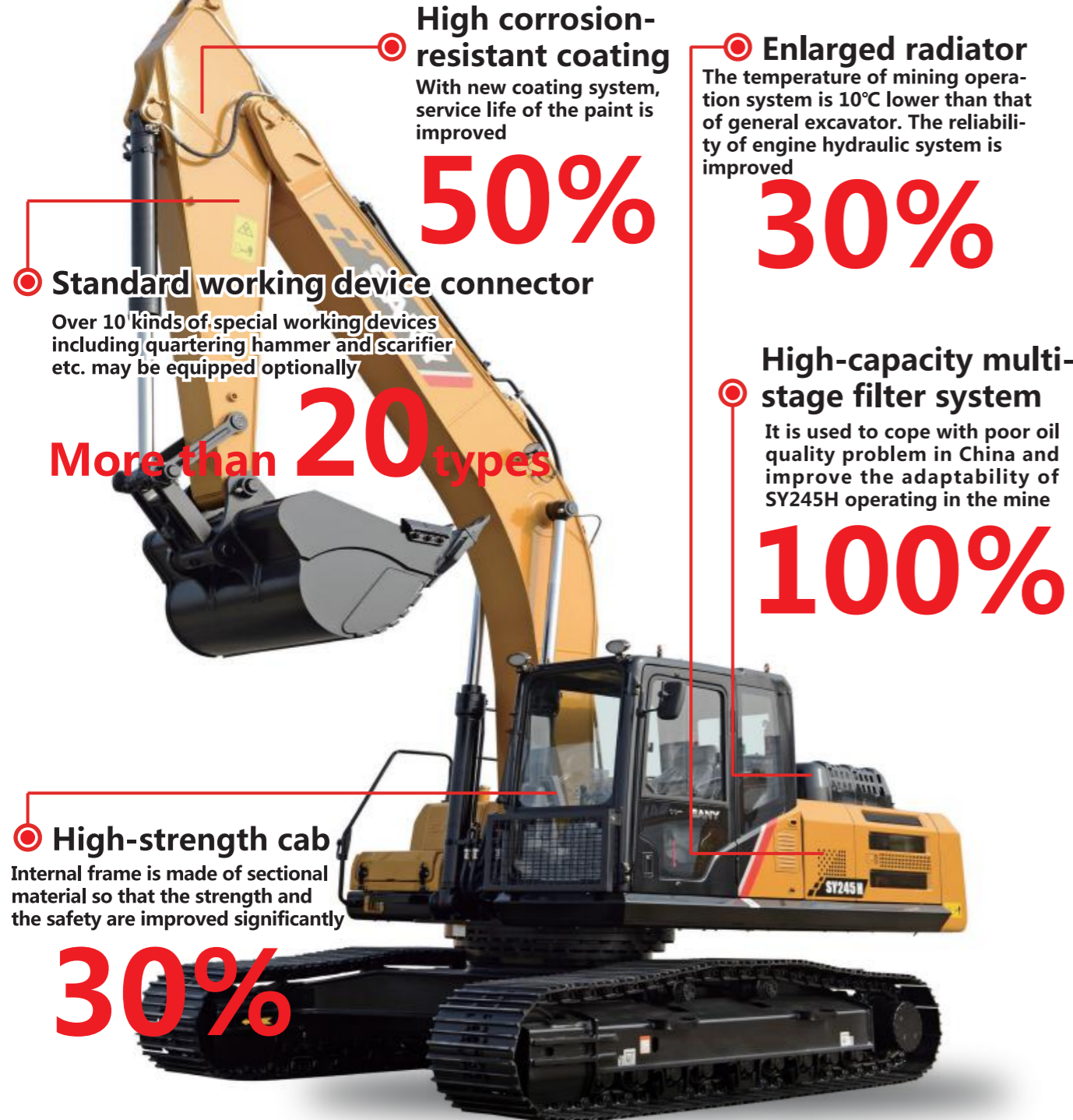

High corrosion-resistant coating
With new coating system, service life of the paint is improved

50%

Enlarged radiator
The temperature of mining operation system is 10°C lower than that of general excavator. The reliability of engine hydraulic system is improved

30%

High-capacity multi-stage filter system
It is used to cope with poor oil quality problem in China and improve the adaptability of SY245H operating in the mine

100%

Standard working device connector

Over 10 kinds of special working devices including quartering hammer and scarifier etc. may be equipped optionally

More than 20 types

High-strength cab

Internal frame is made of sectional material so that the strength and the safety are improved significantly

30%

High corrosion-resistant coating

By cooperating with world known paint brands, aging life of the paint reaches the highest level in the industry. The adaptability is improved by 40%

Comparison of coating endurance test data

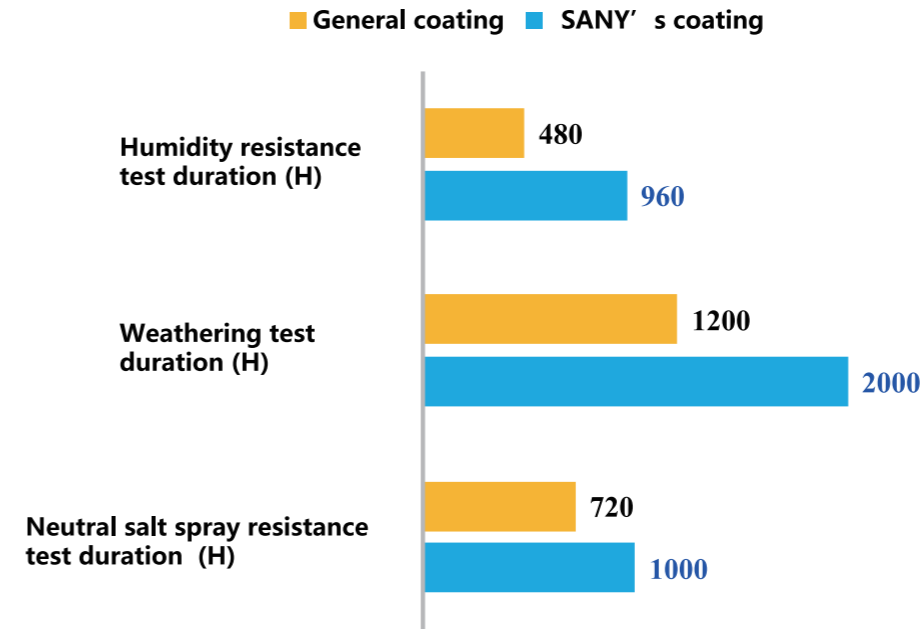

Coating distribution of SANY's high corrosion-resistant paint

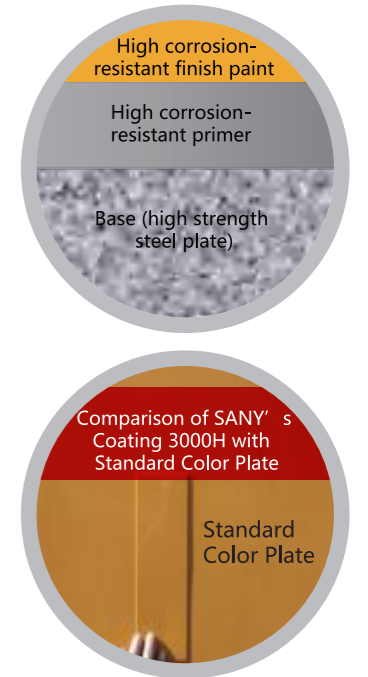

Large-capacity multi-stage filter system

Initiative large-capacity multi-stage filter system is introduced to cope with poor oil quality problem in China and meet emission requirements of national III standard. Filter precision of impurities reaches 99.9% and water separation efficiency is above 95%. Both are higher than industrial standard.

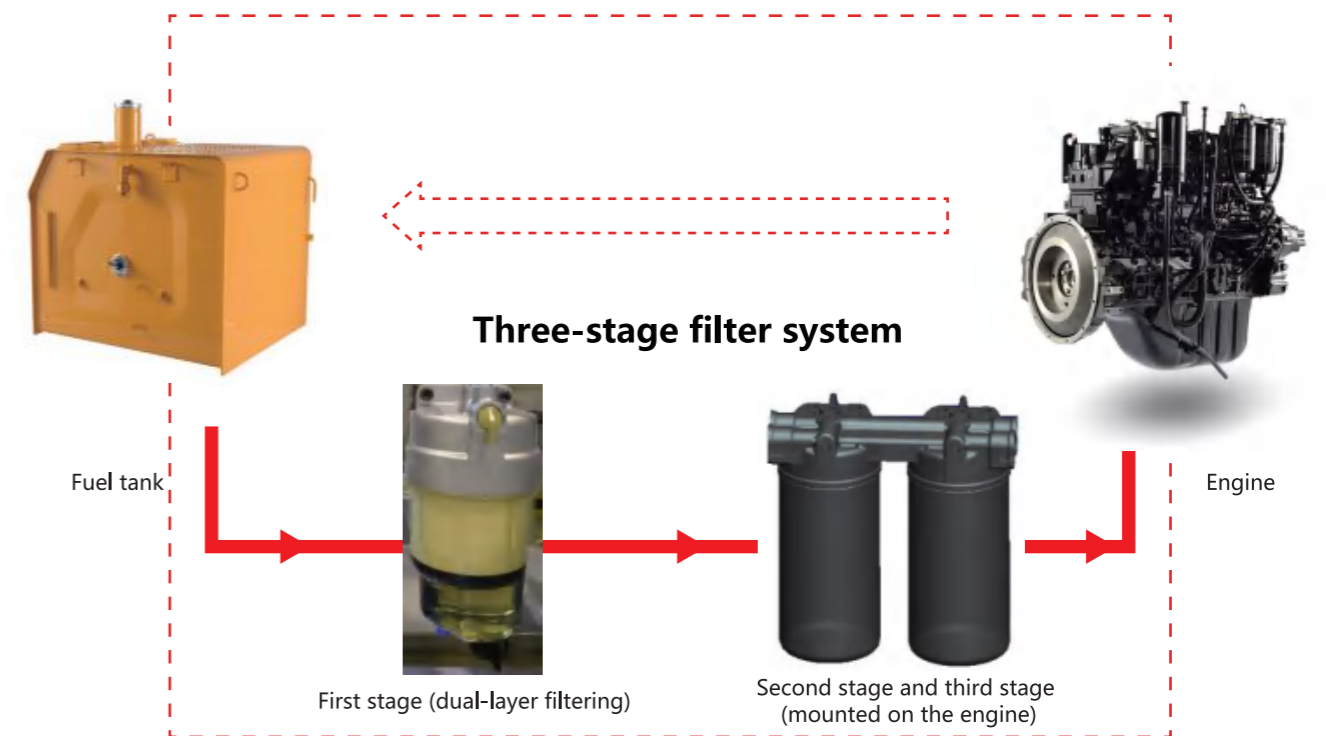

○ Big radiator

Big radiator for 30t grade is used; water radiator and oil radiator are connected in parallel, and are connected to intermediate cooler in series; fuel oil cooler is added. The proportion of hydraulic oil radiator and water radiator cores is increased to ensure that the excavator can work under high temperature and digging force is sufficient. Radiator chamber is connected to air filter chamber, and meanwhile the opening of left door is increase so that the air intake reaches 20%.



○ Plateau adaptability

With high compression ratio and high performance turbocharger, the engine still could maintain good air intake efficiency on the plateau.

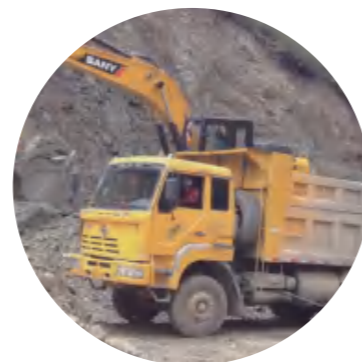
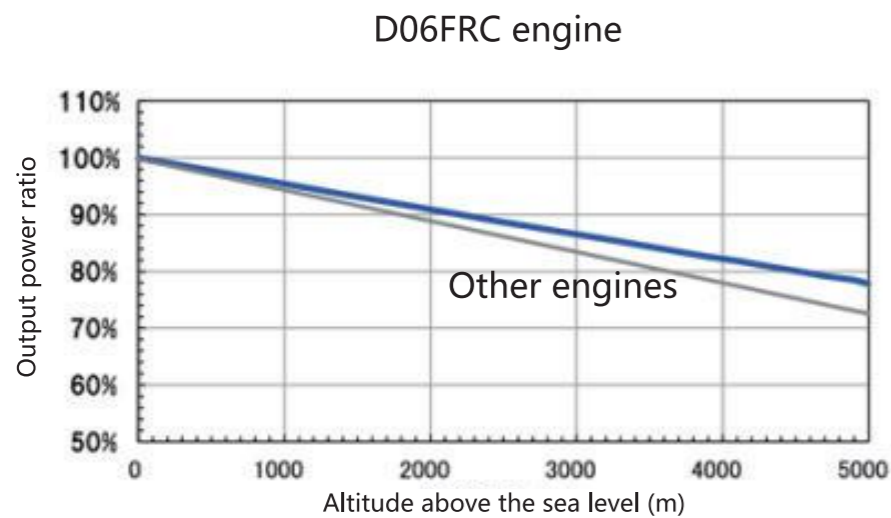

When the operating altitude is above 2300m, the power only reduces by 5% correspondingly if the altitude increases each 1,000m.

When the excavator operates in plateau area, internal program will adjust engine output characteristics automatically according to environmental variations collected. It is unnecessary to replace any spare parts.

(Remark: 14SY024300158 Maqu, Gansu Province; Altitude: 4,500m; the picture is taken on July 15, 2015)

○ High safety

In allusion to mining conditions, frame-type cab of sectional material and newly developed dust control & noise reduction technology are used so that the stability is higher and the safety performance and noise level of the cab are much better than other brands.



○ One machine for several purposes

In allusion to individual demands of the customer, this product may match with over 20 kinds of working devices, and various modified products to improve earning power of the customer.

Boom	5.9m		Bucket capacity m ³
Bucket rod	2.5m	2.95m	
Configuration situation	●	▲	△1.3
	■	■	□1.5

Maximum material density (kg/m³): ● ≤2000; ■ ≤1800; ◆ ≤1500; ▲ ≤1200; - Unavailable

Classification of bucket by use: △: bucket for stonework; □: bucket for earthwork;

The configuration marked in orange is standard configuration of SY245H

Product Introduction

○ Main configuration

Core components like pumps, valves and engine etc. are designed jointly with proprietary intellectual property rights, and are manufactured by world famous manufacturers to ensure high quality and satisfy professional demands of SANY' s customers



D06FR engine meets emission standard and the displacement and the torque are generally 20% higher than foreign brands. It outputs high power and helps the customer to solve the operating difficulties of heavy-duty working condition.



KMX15RB/b45217a-v main valve is customized, is upgraded and optimized on the basis of original KMX15RB and has outstanding advantages including "high reliability, low pressure loss, high flow distribution efficiency and smooth compound control action". It could handle heavy-duty operation conditions for the customer.



K7V125 main pump is customized and has outstanding advantages including "low noise, high efficiency and high pressure"; with high pressure rotating mechanism, the service life of the bearing is improved by 20%. It is more suitable for the operating requirement of large torque for mining conditions.

○ Construction case

Comments of the customer on SY245H : "The appearance is sturdy and elegant and it is very powerful when operating on stonework!"



Worksite: Liyang quarry
Working condition: Stonework
Operating type: blasting – excavation- loading
Work assumed by SY245: Loading

Worksite: Gannan of Gansu Province (altitude above sea level 4000m)
Working condition: Stonework (decomposed rock)
Operating type: excavation- loading
Work assumed by SY245: Stripping stonework and loading



Worksite: Zhangjiajie of Hunan Province, in a cement plant
Working condition: Stonework
Operating type: blasting – excavation- loading
Work assumed by SY245: Loading

Worksite: Weinan of Shaanxi Province, a quarry for highway roadbed
Working condition: Earthwork & stonework
Operating type: excavation- loading
Work assumed by SY245: Stripping stonework and loading



Technical specifications

Specifications		Main performance	
Total weight	25500kg	Traveling speed (high/low)	5.4/3.4(km/h)
Bucket capacity	1.3m ³	Slewing speed	10.6 rpm
		Gradeability	70% (35°)
Engine		Ground pressure	52.5kPa
Model	D06FRC	Digging force of bucket	175kN
Type	Direct injection, 6-cylinder, 4-stroke, turbocharged and water-cooled	Digging force of arm	120kN
Rated power	147kW/2100rpm		
Maximum torque	750Nm/1350rpm		
Displacement	6.373L		

Capacity of oil and coolant		Traveling section	
Fuel tank	475L	Number of track shoes	49
Hydraulic oil	277L	Carrier wheel on each side	2
Engine oil	29L	Thrust wheel on each side	9
Anti-freezing solution	30.9L	Standard track	600mm
Final drive	2×4.0L		

Boom--	5900	mm	Arm--	2950mm	Widthoftrack--	600mm	Counterweight--	4700Kg				
Heightofloadingpoint(B) m	Radiusofloadingpoint(A)								Maximumdistance		m	
	3m		4.5m		6m		7.5m		Loadingcapacity			
	Longitudinal	Transverse	Longitudinal	Transverse	Longitudinal	Transverse	Longitudinal	Transverse	Longitudinal	Transverse		
7.5m	Kg				5981	5981			5999.57	5999.57	6.15	
6.0m	Kg				6083	6083	5775	5673	5669.90	5639.70	7.53	
4.5m	Kg				6242	6242	5838	5682	5665.06	5010.26	8.10	
3.0m	Kg			9459	9459	7856	7502	6724	5385	6120.86	4620.53	8.40
1.5m	Kg			11713	10834	8870	7118	7037	5191	5949.35	4429.29	8.50
Ground	Kg			12789	10477	9541	6859	6892	5049	6113.97	4527.26	8.26
-1.5m	Kg	11091	11091	13080	10367	9574	6879	6953	5108	6703.49	4982.43	7.75
-3.0m	Kg	17705	17705	12543	10457	9339	6974			7930.62	5867.41	6.91
-4.5m	Kg	15261	15261	10814	10766					8623.42	8065.14	5.51

1. The lifting capacity is calculated in accordance with ISO10560 and SAEJ1097, where limit coefficient of hydraulic system is 0.87 and tilting limit coefficient is 0.75;

2. The item with the mark * is limited by hydraulic pressure and the item without the mark "*" is limited by stability;

3. Lifting point is front support hole of bucket rod (excluding the weight of bucket). It is necessary to deduct from the above lifting capacity if additional accessory is installed such as bucket etc.

4. Lifting capacity of SY265C is improved by 1.04 times on the basis of SY245C.

Overall dimensions (mm)

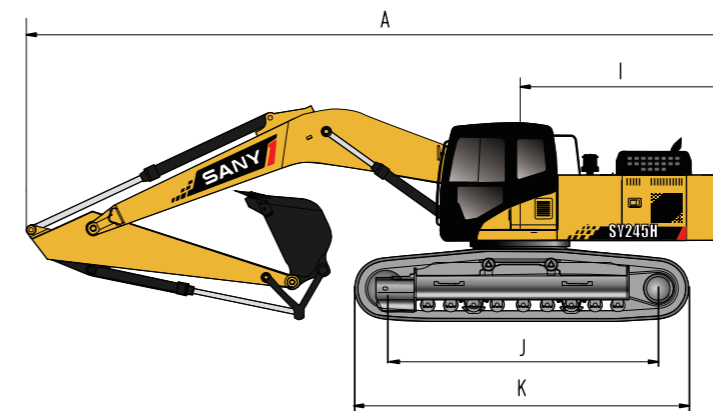
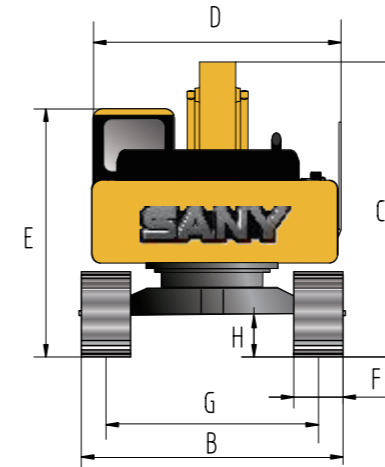

Designation (Unit: mm)	SY245H
A Overall length (in transportation state)	10290
B Overall width	3190
C Overall height (in transportation state)	3255
D Upper width	3045
E Overall height (cab top)	3255
F Width of standard track shoe	600
G Track gauge	2590
H Minimum ground clearance	470
I Slewing radius of tail	3105
J Ground contact length of track	3640
K Track shoe length	4445

Operating range (mm)

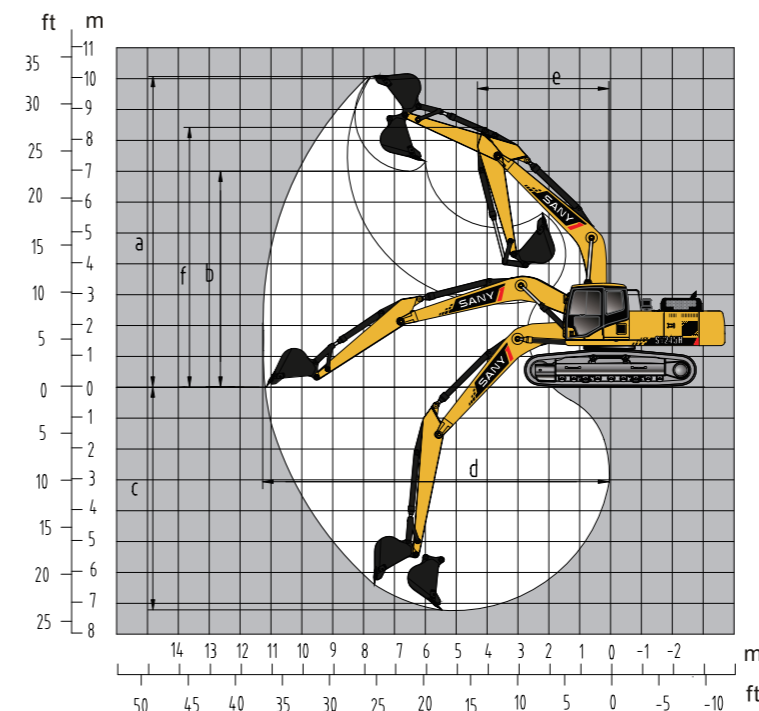

Designation (Unit: mm)	SY245H
a Maximum digging height	9745
b Maximum unloading height	6715
c Maximum digging depth	6705
d Maximum digging distance	10225
e Minimum slewing radius	3800
f Maximum height at minimum slewing radius	8016



SY245H Strive only for Classic Product

New-generation Super Hydraulic Excavator for Mining