



SRC400C1

40 METRIC TON



**MORE THAN
HEAVY LIFTING**

QUALITY CHANGES THE WORLD

V1.1

SRC400C1

ROUGH TERRAIN CRANE

Crane capacity: 40 metric ton at 2.5m radius

Four-section boom: 10m-31.5m

2-stage folding jib: 7.9m, 13.7m

Max. lifting height: 33.9m (Boom) / 47.4m (Jib)

Max. working radius: 28m (Boom) / 32.5m (Jib)

Max. gradeability (at stall): 92%





A NEW COMPACT ROUGH TERRAIN CRANE WITH BETTER CAPACITY

When you consider the quality and value SANY rough terrain cranes deliver over their lifetime, you know that they are simply the best investment you can make.

At SANY, we maintain a total and unwavering commitment to providing technologically advanced products at the best value possible. Within that commitment is a diverse product line, well-funded research and development programs.

Environment friendly and energy saving

New dual working mode of superstructure and carrier
 Dual working mode of engine
 Reducing of noise, oil and heat consumption
 Top class working speed

Item	Mode	Engine speed	Performance
	SS Mode	Max. revs 2200rpm	Oil consumption ↓6% Noise ↓5% Heat consumption ↓6% Contaminant ↓28%
	Carrier Mode	Max. revs 2400rpm	Ensure the maximum traveling speed

Precise control

Electrical proportional joystick: quick reaction in 5ms, providing smooth operation of start and stop
 Joystick stroke can be adjusted from 0%-100% such that the loading can be as precise as mm level.
 Smart flow distribution system, which is initial of flow branching and merging method and improved the micromobility.

Advanced design method

FEA and verification testing
 *Finite Element Analysis

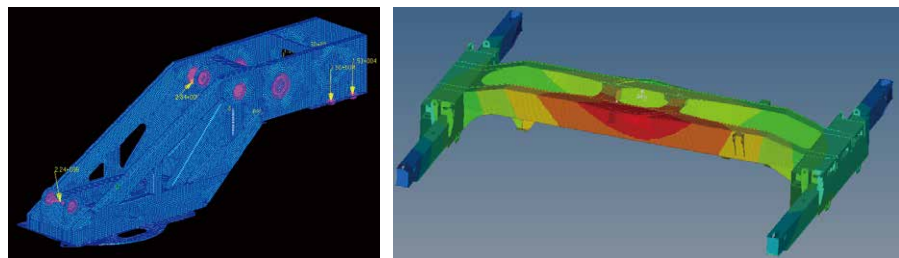

Smart system

10.4 inch touchscreen and multifunctional CAN-BUS panel, which is smarter and more comfortable.
 With the visual instrument, human-computer interaction technology and the fault diagnosis system, the operation of crane is much more convenient.

Crane

The U-type boom is made of high tensile steel with four telescoping sections. The fully extended boom is 31.5m and it can reach the height of 33.9m, which enables the crane with extra reaching ability.

The max. lifting moment of basic boom is 1175kN-m and the max. lifting moment of fully-extended boom is 755 kN-m, improving the load capacity.

Single telescopic cylinder

4 U-shape sections consisting of 1 base section and 3 telescopic sections extending/retracting through single telescopic cylinder plus rope extension mechanism, it is stable and efficient.

Folding jib

The folding lattice jib can be offset at 0°, 15°, 30° to enable the crane to carry out jobs under different load conditions and improve the efficiency.

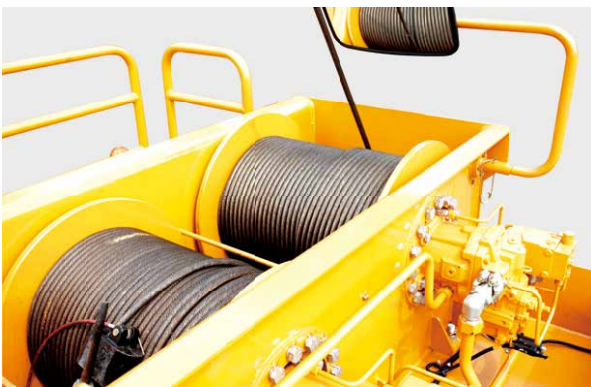

Two winches with cable follower

Main winch and auxiliary winch with powerful line pull operate at high speeds, serving to enhance work efficiency.

*Maximum permissible line pull may be affected by wire rope strength.

Winch

Main hook: 320kg

Aux. hook: 85kg

Main winch wire ropes: 16mmx165m (Diameter x length)

Aux. winch wire ropes: 16mmx135m (Diameter x length)

Operator Comfort

The smart control BUS display allows operator to simultaneously monitor the travelling and operating condition. It is easy to drive and operate.

The new wider cab is self-developed by SANY, which made of corrosion-resistant steel with sliding door access and safety glass windows.

Equipped with:

- Soft interior seat and decoration
- Full-vision skylight
- Adjustable cushioned seat
- Air conditioner
- Electrical windshield wiper and washer
- LMI display screen

*The LMI display screen achieves the combination of control console and operating display, which clearly shows the data under all working conditions.

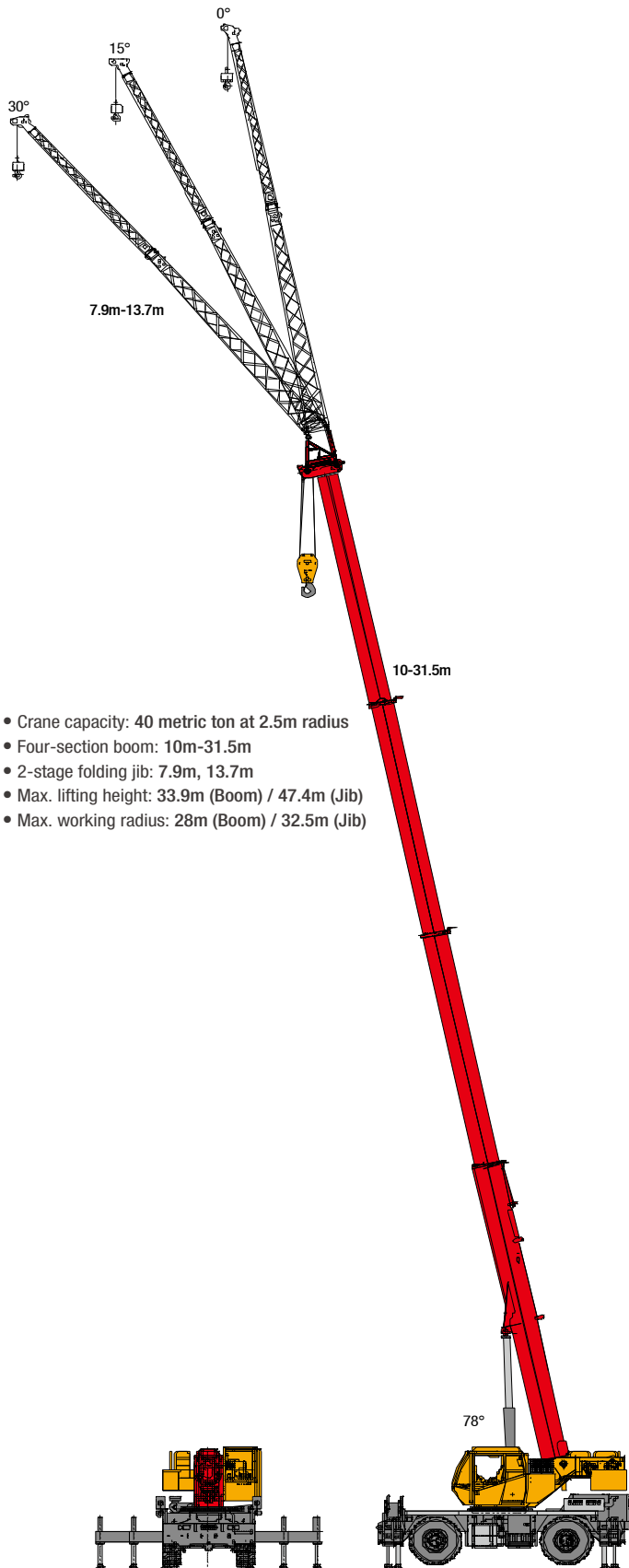
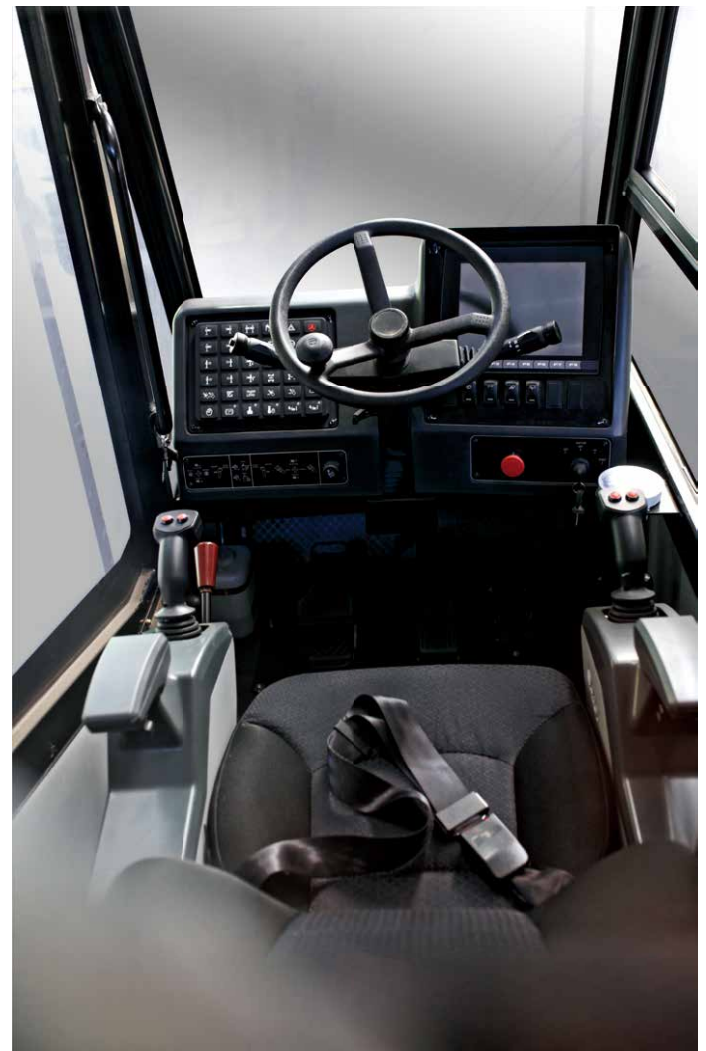

- Crane capacity: 40 metric ton at 2.5m radius
- Four-section boom: 10m-31.5m
- 2-stage folding jib: 7.9m, 13.7m
- Max. lifting height: 33.9m (Boom) / 47.4m (Jib)
- Max. working radius: 28m (Boom) / 32.5m (Jib)

Counterweight

Fixed counterweight: 4000kg.



Tires Size 20.5-25

Carrier

Chassis: Four drive modes, the max. travel speed is 40km/h and the max. gradeability is 92%(at stall), showing excellent performance.

- Wheel formula
- 4 X 4 drive mode
- The steering system is all hydraulic and has four modes of steering:
- Independent front
- All wheel steer
- Four wheel "crab"
- Independent rear

The min. steering radius is 6.2m and the min. ground clearance is 348mm, improving the trafficability of the crane.

Outriggers

H-type structure, 4-point support. Vertical jack cylinder equipped with bi-directional holding valve to ensure safety. Outrigger span: 6.7m x 6.5m (longitudinal x traverse)

Steps



Right

Left

Front

Rear



Control system

Electrical control system with imported joystick and BUS connecting provides excellent maneuverability and reliability. It is easy to maintain and troubleshoot.

The independently developed SYMC* and CAN-BUS technology ensure stable signal communication.

All-round safety system: the main and auxiliary winches equipped with 3-wrap protector and A2B system to prevent over hoist and tipping.

With comprehensive logic and interlock control and automatic cutting off of dangerous motion, safe and reliable operation is realized.

LMI: Smart load moment indicator system to ensure the working safety, accurate and smooth operation.

The smart LMI with the accuracy within 0% to 10% ensure the working safety.

*SYMC (Sany motion control) is the control system self-developed by Sany.

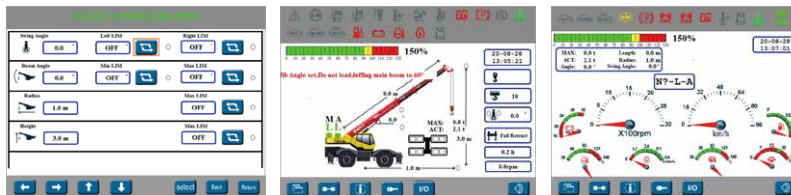

Hydraulic system

Key hydraulic components such as pumps, main valves, motor and counterweight valves, are high quality and reliable. Load sensing variable displacement piston pump can adjust displacement.

The hydraulic system is equipped with counterbalance valve, relief valve, bi-directional holding valve to realize stability and reliability.

Engine

Type: Dongfeng Cummins QSB6.7 C260 31

Rated power: 194kW/2400rpm

Emission: EU Stage IIIA Standard

Fuel tank: 300L

Electrical system

2*12V maintenance-free battery with a mechanical power switch, the overall power can be cut off manually.

Technical Parameters

Axle load

Axle	Front	Rear	Weight
Axle load/t	15.1	15.6	30.7

Note: With the hook blocks suspend on boom nose.

Hook

Rated load/t	Number of sheaves	Rope rate	Hook weight /kg
40	4	8	320
5	-	1	85

Operation

Item	Parameter	Diameter/Length	Max. single line pull
Main winch	Single-rope speed 0-150 m/min	16 mm/165 m	5.3 t
Aux. winch	Single-rope speed 0-150 m/min	16 mm/135 m	5.3 t
Slewing		0-2.7r/min	
Luffing up/down		34 s/52 s	
Boom extending/retracting		36 s/43 s (10 m-31.5 m)	
Outrigger	Outrigger jack	Retract	25 s
		Extend	25 s
	Outrigger beam	Retract	25 s
		Extend	25 s

Overall Dimensions

Unit: mm

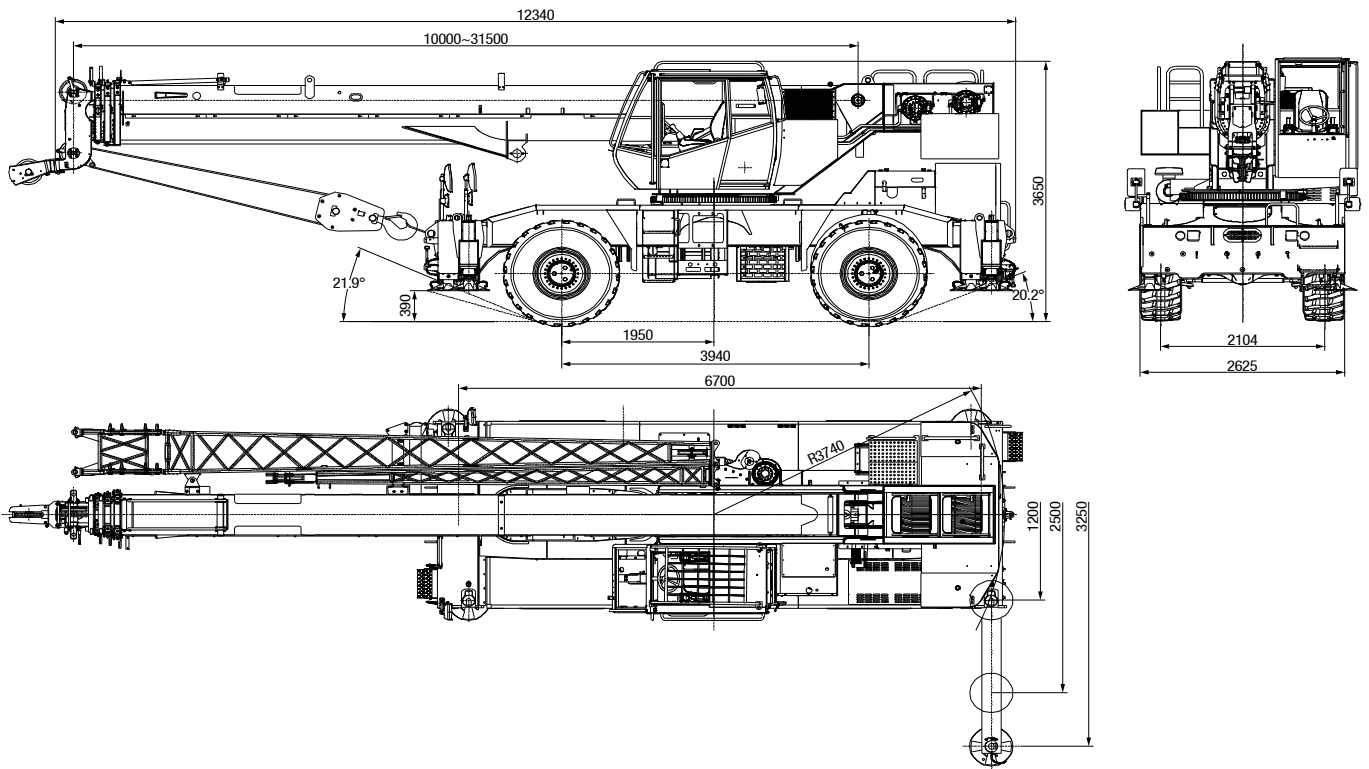

Technical Specification

Category	Item	Unit	Value
Capacity	Max. lifting capacity	t	40
Weight	Gross weight	kg	30700
Power	Engine model (Emission standard)	-	Dongfeng Cummins QSB6.7 C260 31
	Max. engine power	kW/rpm	194/2400
	Max. engine torque	N·m/rpm	990/1500
Dimensions	Overall length	mm	12340
	Overall width	mm	2625
	Overall height	mm	3650
Travel	Max.travel speed	km/h	40
	Min. steering radius(2W/4W)	m	12.2 / 6.2
	Approach angle	°	21.9
	Departure angle	°	20.2
	Max. gradeability	%	92
	Fuel consumption per 100km	L	50

Category	Item	Unit	Value	
Main Performance	Working temperature range	°C	-20~+46	
	Min. rated lifting radius	m	2.5	
	Tail slewing radius	m	3.74	
	Max. lifting moment	Basic boom	kN·m	1175
		Full-extension boom	kN·m	755
		Full-extension boom+jib	kN·m	457
	Boom length	Basic boom	m	10
		Full-extension boom	m	31.5
		Full-extension boom+jib	m	45.2
	Max. lifting height	Basic boom	m	12.9
		Full-extension boom	m	33.9
Full-extension boom+jib		m	47.4	
Outrigger span (Longitudinal×Transverse)	m	6.7×6.5		
Jib offset	°	0,15,30		
Operation speed	Max. single rope lifting speed of main winch (empty load)	m/min	150	
	Max. single rope lifting speed of auxiliary winch (empty load)	m/min	150	
	Full extension/retraction time of boom	s	36/43	
	Full luffing up/down time of boom	s	34/52	
	Slewing speed	r/min	0~2.7	
Air conditioner	in operator's cab	-	Heating & cooling	

Load Chart—Telescopic Boom

Unit: kg



Boom length(m) Radius(m)	10	12.19	15.24	18.29	21.34	24.38	27.43	31.5	Boom length(m)- Radius(m)
2.5	40000								2.5
3	35000	23000	22000						3
3.5	31500	23000	22000	21500					3.5
4	29200	23000	22000	20600					4
4.5	26200	22000	22000	20200	18500				4.5
5	23800	20500	20300	19000	17500				5
5.5	21800	19500	18500	17600	16200				5.5
6	19000	17500	17000	16200	15000	14200	13200		6
6.5	17300	16000	15600	15200	14200	13500	12300		6.5
7	15800	14700	14400	14200	13500	12700	11500	9000	7
7.5	14300	13500	13400	13300	12700	12000	10800	8600	7.5
8		12600	12500	12400	12000	11400	10200	8400	8
9		11000	10800	10700	10600	10200	9200	8000	9
10			8800	9350	9450	9250	8300	7500	10
12			6700	7150	7300	7250	6600	6400	12
14				5300	5500	5550	5600	5500	14
16				4050	4250	4300	4400	4500	16
18					3300	3350	3400	3450	18
20						2600	2650	2700	20
22							2150	2200	22
24							1650	1700	24
26								1350	26
28								1050	28
Min. boom angle at empty load(°)	0	0	0	0	0	0	0	0	Min. boom angle at empty load(°)
Load at 0° boom angle	11300	8200	5100	3400	2300	1600	1000	500	Load at 0° boom angle
Rope rate	8	6	6	4	4	4	4	3	Rope rate

Load Chart–Telescopic Boom

Unit: kg



Boom length(m) Radius(m)	10	12.19	15.24	18.29	21.34	24.38	27.43	31.5	Boom length(m) Radius(m)
2.5	40000								2.5
3	35000	23000	22000						3
3.5	31500	23000	22000	21000					3.5
4	27000	21800	20800	19800					4
4.5	22000	20200	19200	18200	18000				4.5
5	19600	18000	17500	16800	16600				5
5.5	16900	16000	15700	15600	15500				5.5
6	14200	14300	14200	14100	14000	13800	10500		6
6.5	12200	12500	12600	12800	12900	12800	10000		6.5
7	10600	11000	11300	11500	11700	11800	9500	8600	7
7.5	9200	9600	9900	10200	10400	10500	9000	8600	7.5
8		8300	8900	9150	9300	9400	8500	8250	8
9		6700	7100	7300	7500	7600	7450	7400	9
10			5800	6050	6200	6300	6350	6400	10
12			3850	4150	4300	4400	4500	4600	12
14				2950	3100	3200	3250	3350	14
16				2100	2250	2300	2400	2500	16
18					1600	1700	1750	1850	18
20						1200	1300	1350	20
22						800	900	950	22
Min. boom angle at empty load(°)	0	0	0	0	0	0	27	38	Min. boom angle at empty load(°)
Load at 0° boom angle	7000	4500	2700	1600	900	500			Load at 0° boom angle
Rope rate	8	6	6	4	4	4	4	3	Rope rate

Load Chart–Telescopic Boom

Unit: kg



Boom length(m) Radius(m)	10	12.19	15.24	18.29	21.34	24.38	27.43	31.5	Boom length(m) Radius(m)
2.5	25000								2.5
3	23000	22600	22000						3
3.5	17300	17700	18000	17000					3.5
4	13500	14000	14500	14700					4
4.5	10300	11000	11500	11800	12000				4.5
5	8800	9500	9900	10100	10200				5
5.5	7600	8100	8400	8600	8700				5.5
6	6500	6900	7000	7200	7400	7450	7500		6
6.5	4800	5800	6100	6300	6450	6600	6700		6.5
7	4300	5200	5300	5500	5700	5850	5900	5950	7
7.5	3750	4500	4750	4800	4900	5050	5100	5150	7.5
8		3650	4000	4200	4350	4500	4550	4650	8
9		2700	3050	3250	3400	3500	3600	3650	9
10			2350	2550	2700	2800	2900	2950	10
12			1350	1500	1600	1750	1800	1900	12
14				900	1000	1100	1150	1200	14
Min. boom angle at empty load(°)	0	0	0	28	40	47	52	57	Min. boom angle at empty load(°)
Load at 0° boom angle	2700	1450	550						Load at 0° boom angle
Rope rate	6	6	6	4	4	4	4	3	Rope rate

Load Chart–Telescopic Boom

Pick and Carry, Load Over Front Unit: kg



Boom length(m) Radius(m)	10	12.19	15.24	18.29	Boom length(m) Radius(m)
3	12400	12300			3
3.5	11100	11000			3.5
4	9900	9850			4
4.5	9000	8900	8800		4.5
5	8000	8100	8200		5
5.5	7200	7400	7600		5.5
6	6400	6600	6750	6800	6
6.5	5800	6050	6200	6250	6.5
7	5250	5550	5700	5750	7
7.5	4750	5050	5200	5250	7.5
8		4600	4800	4850	8
9		3900	4050	4100	9
10			3450	3550	10
12			2450	2550	12
14				1850	14
16				1200	16
Min. boom angle at empty load(°)	0	0	0	0	Min. boom angle at empty load(°)
Rope rate	4	4	4	4	Rope rate

Remark: Travelling speed shall be less than 4km/h to ensure operation safety.

Load Chart–Telescopic Boom

On Tires Stationary, Load Over Front Unit: kg



Boom length(m) Radius(m)	10	12.19	15.24	18.29	Boom length(m) Radius(m)
3	14000	14300	14500		3
3.5	12200	12300	12500		3.5
4	10800	11000	11200		4
4.5	9800	9900	10000	10200	4.5
5	8700	9000	9100	9200	5
5.5	7800	8200	8300	8400	5.5
6	7000	7400	7700	7800	6
6.5	6400	6700	7200	7300	6.5
7	5600	6100	6500	6600	7
7.5	4800	5600	5900	6000	7.5
8		4900	5200	5400	8
9		4000	4300	4400	9
10			3500	3600	10
12			2500	2600	12
14				1900	14
16				1300	16
Min. boom angle at empty load(°)	0	0	0	0	Min. boom angle at empty load(°)
Rope rate	4	4	4	4	Rope rate

Load Chart–Telescopic Boom

On Tires Stationary Unit: kg



Boom length(m) Radius(m)	10	12.19	15.24	18.29	Boom length(m) Radius(m)
3	11000	11000	10500		3
3.5	9700	9700	9700		3.5
4	8350	8600	8700		4
4.5	7200	7350	7500	6300	4.5
5	6200	6300	6500	5800	5
5.5	5250	5350	5600	5300	5.5
6	4250	4450	4650	4700	6
6.5	3550	3850	4050	4100	6.5
7	2950	3300	3550	3600	7
7.5	2350	2750	3050	3100	7.5
8		2300	2650	2700	8
9		1800	1900	2050	9
10			1350	1600	10
12			850	900	12
Min. boom angle at empty load(°)	0	0	24	40	Min. boom angle at empty load(°)
Rope rate	4	4	4	4	Rope rate

Working Range – Telescopic Boom

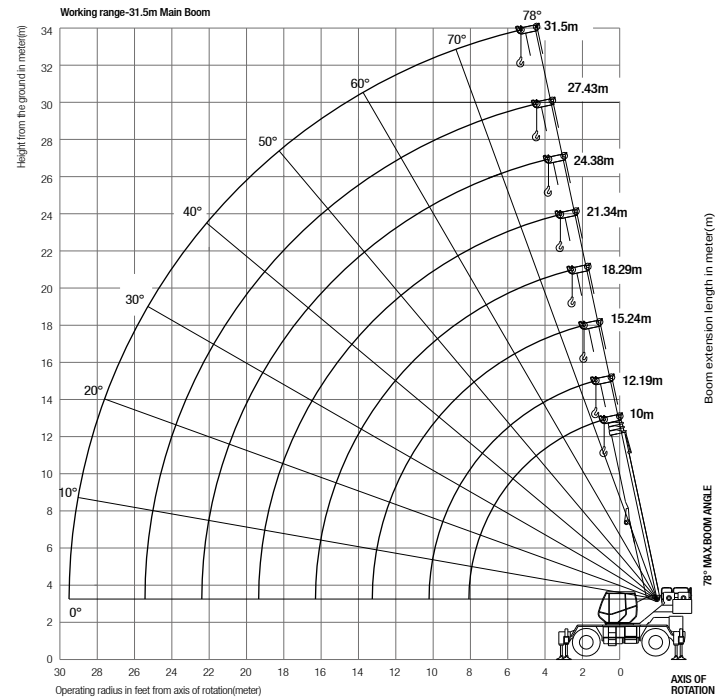

Load Chart-Jib

Unit: kg



Boom angle(°)	31.5m+7.9m						31.5m+13.7m						Boom angle(°)
	Jib offset angle						Jib offset angle						
	0°		15°		30°		0°		15°		30°		
	kg	Radius(m)	kg	Radius(m)	kg	Radius(m)	kg	Radius(m)	kg	Radius(m)	kg	Radius(m)	
78	3800	7.6	2900	9.3	2200	10.8	2100	8.7	1600	12.1	1200	14.8	78
76	3700	9	2750	10.7	2150	12.1	2050	10.3	1550	13.7	1150	16.4	76
74	3600	10.4	2650	12	2050	13.4	2000	11.9	1500	15.2	1100	17.8	74
72	3400	11.8	2550	13.3	2000	14.7	1950	13.5	1450	16.7	1100	19.2	72
70	3200	13.2	2450	14.6	1950	16	1900	15.1	1400	18.2	1100	20.6	70
68	3050	14.5	2350	15.9	1900	17.2	1800	16.6	1350	19.7	1050	22	68
66	2900	15.8	2250	17.2	1800	18.4	1700	18.1	1300	21.1	1000	23.3	66
64	2700	17.1	2150	18.4	1750	19.6	1600	19.6	1250	22.5	1000	24.6	64
62	2550	18.3	2050	19.5	1700	20.8	1500	21.1	1200	23.9	950	25.9	62
60	2400	19.4	1950	20.6	1650	21.9	1450	22.5	1150	25.2	950	27.1	60
58	2250	20.5	1800	21.7	1600	23.1	1400	23.9	1100	26.4	950	28.3	58
56	2000	21.6	1700	22.8	1500	24.1	1300	25.1	1050	27.6	950	29.5	56
54	1800	22.7	1600	23.8	1400	25.1	1200	26.3	1000	28.8	900	30.6	54
52	1600	23.7	1450	24.8	1300	26	1100	27.5	950	29.9	900	31.5	52
50	1450	24.7	1300	25.8	1200	26.9	1000	28.7	900	31	850	32.5	50
Min. boom angle	32		34		35		34		37		39		Min. boom angle

Working Range-Jib

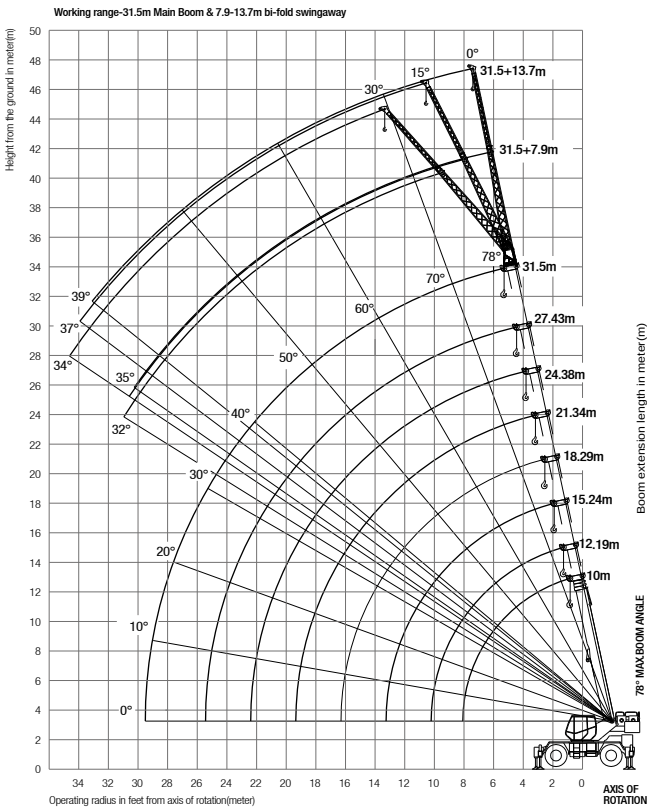

Sany Automobile Hoisting Machinery Co., Ltd.

No.168, Jinzhou Avenue, Jinzhou Development Zone, Changsha, Hunan, China Postcode: 410600
 Service: 0086-400 6098 318 Hotline: 400 8879 318
 Email: crd@sany.com.cn

Reminder:
 For safe and reliable operation of the diesel engines, please fill Grade IV machines with Grade IV diesel and urea solution conforming to related national standards. Please refer to the operating instructions and related standards for details.

Any change in the technical parameters and configuration due to advancement in technology may occur without prior notice. The machine in the figures may include auxiliary equipment. This brochure is for reference only, and goods in kind shall prevail.
 Copyright at Sany Heavy Industry. No part of this catalogue may be copied, recorded or used for any purpose without written approval from Sany Heavy Industry.

© Printed in December 2021 in China

www.sanyglobal.com

