

SANY[®]

SPECIFICATION



 250t

 73m

 108.5m

SAC2500C7

SANY ALL TERRAIN CRANE

QUALITY CHANGES THE WORLD

crane.sanyglobal.com

DEMO

It is one of the core business units in SANY Group, specializing in the development and manufacturing of high-end wheel cranes, crawler cranes and tower cranes, including the complete range of wheel cranes from 8 to 2400t, crawler cranes from 25 to 4500t and tower cranes from 6 to 185t.



SANY CRANE



SAC2500C7

SANY ALL TERRAIN CRANE
250 TON LIFTING CAPACITY

7-section 73m boom and fixed jib 22m are standard, and the jib can be added up to 36m with two optional 7m inserts, delivering super strong lifting performance.

80t full counterweight. 20.5t counterweight can be carried on board when traveling from jobsite to jobsite.

Chassis DF Cummins QSZ13-C525-30 engine / FAST transmission / Zhuzhou Gear Transfer case / HanDe axles (disc brake).

5-axle all-terrain carrier, H-type outriggers, hydro-pneumatic suspension, all-wheel steering, 6 steering modes, minimum steering radius of 10m.

Independent hydraulic systems for crane and chassis (independent hydraulic system for crane operation consisting of variable piston pump + slewing pump + auxiliary pump + fluid tank), ensuring higher efficiency and better maneuverability. Cable wiring for superstructure, IP67, easy maintenance with high reliability.







i-Cab - Driver's cab

- Multi-function seat with air suspension, making driving more comfortable.
- Double seats and foldable berth for the co-driver.
- 10.1-inch touch screen integrated with back-up image and multi-media.
- Electric rearview mirror with electric heating, ensuring good field of view in foul weather.
- Adjustable high-brightness LED headlamps/fog lamps, providing clear vision at night.
- Full-automatic HVAC, able to automatically adjust indoor temperature as demanded.

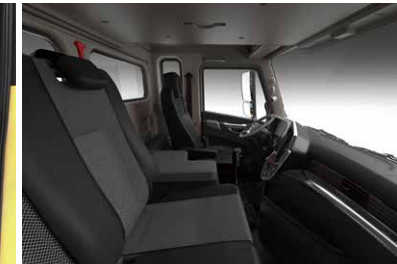



i-Cab - Operator's cab

Seat widened by 480mm, and leg room increased by 30%.

Cab tiltable by 0-20°, relieving cervical fatigue during large-angle and long-boom operations.

Adjustable seat with maximum inclination of 140°, allowing the operator to lie flat and rest after work

Electric seat linked with armrest box, enabling multi-dimensional adjustment for enhanced comfort.

Electronic control joysticks, making operation easier.

45° tilted silicone button panel, easy to reach and operate.

70° openable front window convenient for ventilation and escape; in compliance with CE standards.

Sliding door, more convenient for getting on/off the cab and opening/closing the door.

Full-automatic HVAC, able to automatically adjust indoor temperature as demanded.



Wireless Remote Control System

Main functions

Outrigger control - outrigger beam and jack telescoping simultaneously or independently, one-key leveling.

Suspension control - suspension locking / unlocking, rising / lowering, unilateral motion for auto leveling.

Superstructure power-on - remote control of power on and off.

Remote ignition and stalling - superstructure / chassis engine start and stop.

One-key light switching - superstructure light switching on, including boom working lamp.

Crane operation control - boom luffing, telescoping, slewing, hoisting, counterweight lifting.

Cab side step telescoping - operator's cab side step extending and retracting.

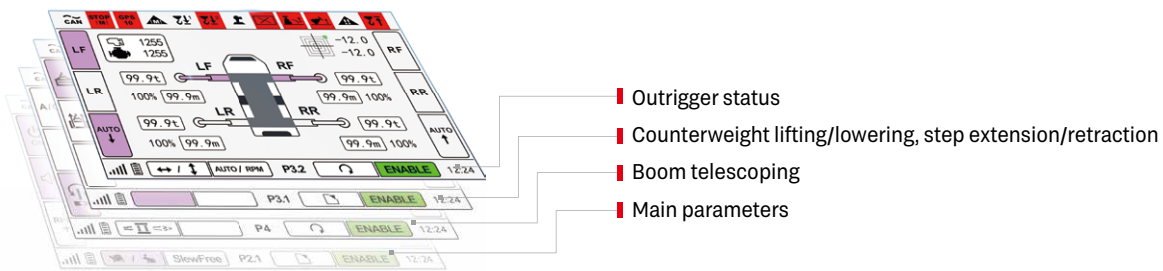

Overall Dimensions

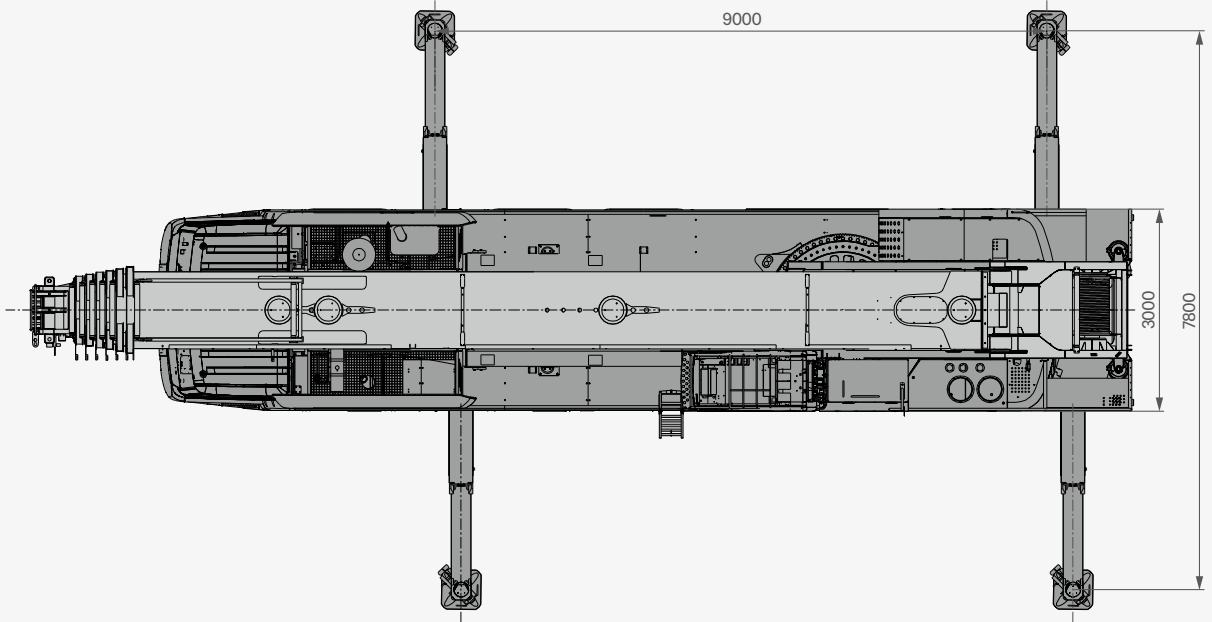
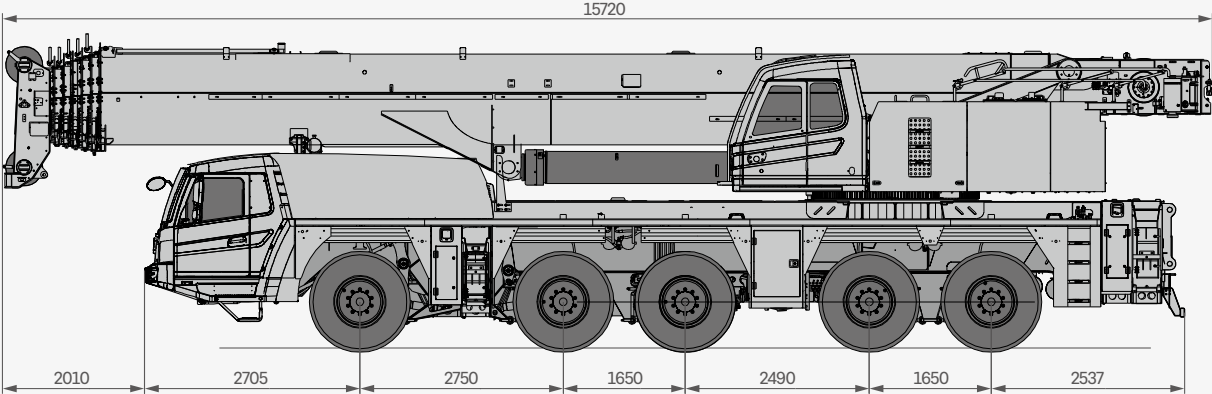

Technical Specification

CATEGORY	ITEM	UNIT	VALUE	
CAPACITY	Max. lifting capacity	t	250	
POWER (CHASSIS)	Max. engine power	kW/rpm	391/1900	
	Max. engine torque	N·m/rpm	2300/1200-1700	
POWER (SUPERSTRUCTURE)	Max. engine power	kW/rpm	194/2200	
	Max. engine torque	N·m/rpm	990/1500	
DIMENSIONS	Overall length	mm	15720	
	Overall width	mm	3000	
	Overall height	mm	4000	
WEIGHT	Gross weight	kg	6000	
TRAVEL	Max. travel speed	km/h	80	
	Min. steering radius (at wheels)	m	10	
	Wheel formula	-	10 × 8 × 10	
	Max. gradeability	%	45	
	Fuel consumption per 100km	L	70	
MAIN PERFORMANCE	Min. rated radius	m	3	
	Tail slewing radius	m	4.85	
	Number of boom sections	-	7	
	Boom shape	-	Oval	
	Max. lifting moment	Basic boom	t·m	756
		Full-extension boom	t·m	285
	Boom length	Basic boom	m	13.8
		Full-extension boom	m	73
		Max. combination of boom +jib	m	Standard: 95 / Optional: 109
	Max. lifting height	Basic boom	m	14
		Full-extension boom	m	72.5
		Max. combination of boom +jib	m	Standard: 94.5 / Optional: 108.5
Outrigger span (longitudinal × transverse)	m	9.0 × 7.8		
Jib offset	°	0, 20, 40		
OPERATION SPEED	Max. lifting speed of single rope of main winch (empty load)	m/min	130	
	Max. lifting speed of single rope of auxiliary winch (empty load)	m/min	130	
	Fully extension/retraction time of boom	s	660/660	
	Full luffing up/down time of boom	s	60/115	
	Slewing speed	r/min	1.5	
AIRCONDITIONER	Superstructure	-	Heating and cooling	
	Chassis	-	Heating and cooling	

Technical Specification



Axle Load

Axle	1	2	3	4	5	Gross weight
Axle load (t)	≤12	≤12	≤12	≤12	≤12	60
Remark	Some parts shall be removed to achieve axle load as above.					



Hook

Load /t		Number of sheaves	Rope rate	Hook weight/kg
160	○	9	19	2065
125	○	7	15	1491
80	●	3	7	693
32	○	1	3	505
12.5	●	0	1	270

● Standard ○ Optional

Counterweight Combinations

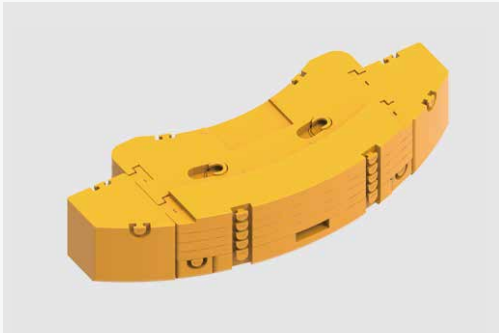

Total weight	①	②	③	④	⑤	⑥	⑦	⑧	⑨
	15t	2.75t	2.75t	10t	10t	10t	11.5t	9t	9t
0t									
15t	•								
20.5t	•	•	•						
30.5t	•	•	•	•					
40.5t	•	•	•	•	•				
50.5t	•	•	•	•	•	•			
62t	•	•	•	•	•	•	•		
80t	•	•	•	•	•	•	•	•	•

Crane Introduction

Carrier

Driver's cab

- Independently developed by Sany, it is of new steel structure, enabling high damping and sealing performance. It is configured with outward opening doors on both sides, air-suspension driver seat and passenger's seat, adjustable steering wheel, wide-angle rearview mirror, comfortable driver seat headrest, antifogging fan, HVAC, stereo radio, and a complete set of controls and instruments, creating a more comfortable, safe and user-friendly driving environment.

Carrier frame

- Designed and manufactured by Sany, it is a anti-torsion box structure welded by fine-grained high-strength steel plates with strong load-bearing capacity.

Chassis engine

- Model: DF Cummins QSZ13-C525-30, conforming to EU Stage IIIA emission standard.
- Output power: 391kW/1900rpm.
- Max. torque: 2300N·m/(1200~1700)rpm.
- Fuel reservoir capacity: 550L.

Transmission

- FAST transmission with hydraulic retarder, 12 speeds forward and 2 speeds reverse.

Axle

- Hande axles are adopted, with all axles available for steering, and axles 1, 2, 4 and 5 for driving. Axles 1 and 2 are equipped with linkage-feedback hydraulic power steering system, and axles 3, 4 and 5 are equipped with electro-hydraulic steering system, providing steering control assist and several special steering modes for your option, and ensuring nimble steering and flexible control.

Drive/Steering

- 10 × 8 × 10.

Suspension system

- All axles adopt height-adjustable hydro-pneumatic suspension with hydraulic lock. The suspension can be adjusted up by 140mm and down by 150mm, and has such modes including suspension, rigid locking, automatic leveling, vehicle lifting/lowering to adapt to various harsh working conditions and road surfaces, ensuring good NVH and lateral stability, and making the driving more comfortable.

Tires

- 385/95R25 radial tire.

Brake

- Parking brake: The parking brake acts on axles 2-5 by the energy-stored spring.
- Service brake: All wheels adopt air servo brakes, forming a dual-circuit braking system. Disc brake is applied for all wheels.
- Assist brake: Transmission hydraulic retarder brake, which can reduce the wear of brake system and save the use costs.

Steering

- Servo power steering gear, dual-circuit hydraulic power steering system with emergency steering pump.
- 6 steering modes: 1) on-road steer (default); 2) all-wheel steer; 3) crab; 4) anti-yaw steer; 5) independent rear axle steer; 6) rear axle lock steer.

Outrigger

- H-shaped outriggers with a longitudinal and transverse span of 9.0m × 7.8m and automatic leveling function are equipped, and they are extended and retracted by the fully hydraulic horizontal/vertical outrigger cylinders.

Electrical system

- Modern data bus system, 24V DC power supply, and 2 battery packs with a single capacity of 180AH are provided, allowing for power cutoff of chassis.
- The chassis adopts CAN bus system, multi-functional centralized display system with low power consumption, and LCD screen with contrast adjustable.

Crane Introduction

superstructure



Operator's cab

- With the angle adjustable within 0°~20°, it adopts the corrosion-resistant steel plate, and is equipped with full-coverage softening interior decoration, panoramic skylight, adjustable seat and other user-friendly designs, making operation more comfortable and easier. The moment limiter display is configured to realize the coordination of the console and the operation display system, so that all working condition data can be clear at a glance.



Superstructure engine

- Model: DF Cummins QSB6.7 194kW six-cylinder, water-cooled diesel engine, conforming to EU Stage IIIA emission standard.
- Fuel reservoir capacity: 285L.



Boom system

- Boom: 7-section boom of oval cross section made of fine-grained high-strength steel plate, with a full-extension length of 73m.
- Jib: 22m long jib of mechanical luffing is installed as standard, and two extensions of 7m long are optional, with offsets of 0°/20°/40° available.
- Telescopic mechanism: The independent hydraulic telescopic mechanism allows for a full extension/retraction time down to 660s, more efficient, safe and reliable.



Hoist

- The main winch adopts an electric proportional variable plunger motor, providing good hoisting micromobility and stability.



Luffing system

- The self-weight luffing down system is more energy saving. The single cylinder + front hinged support arrangement makes the luffing more labor-saving and improves the stressing condition of the boom; an electric proportional control balance valve is adopted.



Slewing

- The slewing system is applied with piston main pump, and supports 360° slew at a speed of 0~1.5r/min; the electric proportional closed hydraulic circuit and electric proportional pedal are applied for emergency braking.



Slewing platform

- Independently designed by Sany, it is made of fine-grained high-strength steel plates, with optimized structure.



Counterweight

- Combined counterweights are applied, totaling 80t. 20.5t counterweight can be carried on board when traveling from jobsite to jobsite. The counterweights can be self-loaded and unloaded via remote control.



Hydraulics

- Key hydraulic elements including main pump, slewing pump, main valve, winch motor and balance are of high quality, ensuring the stability and reliability of the hydraulic system; the accurate parameter matching further improves the operation performance valve; Electric proportional displacement piston pump is applied, and the pump displacement is adjusted in real-time by changing the opening of electric control lever, realizing high-precision flow control and reducing the energy consumption; Innovative dual-pump shunt/confluence main valve enables higher dual-pump confluence efficiency in case of single action and better dual-pump shunt control in case of combined actions.
- Self-weight compensated luffing down hydraulic system is adopted, ensuring better luffing-down micromobility and stability.
- Single-cylinder bolt telescoping system is applied for the boom.
- The slewing system is of closed type, and the flow rate and the flowing direction are changed by adjusting the variable pump swash plate, providing better slewing micromobility and stability.



Control system

- The crane is electronically controlled through the moment limiter system (PLC control); two multi-directional levers can return to the original position automatically; the movement of the crane is adjusted by regulating the hydraulic pump, and the speed is adjusted by regulating the speed of the engine.



Safety equipment

- Moment limiter: The moment limiter calculation system is developed by using the mechanics analysis method based on the hoisting mechanical model, and the rated hoisting accuracy is controlled within $\pm 5\%$ through online no-load calibration, enabling all-round protection for the hoisting operations; in case of overloading operations, the system will send an alarm automatically to provide safety guarantee for operations.
- Hydraulic balance valve, overflow valve, two-way hydraulic lock and other elements provided for the hydraulic system, ensuring good stability and reliability of the hydraulic system.
- 3rd wrap indicator of main winch to prevent rollover of wire rope.
- A2B limit switch mounted at tip of boom and jib to prevent over-hoisting of the wire rope.
- Anemometer mounted at tip of boom to check if the wind speed is out of the allowable operating range of the crane.

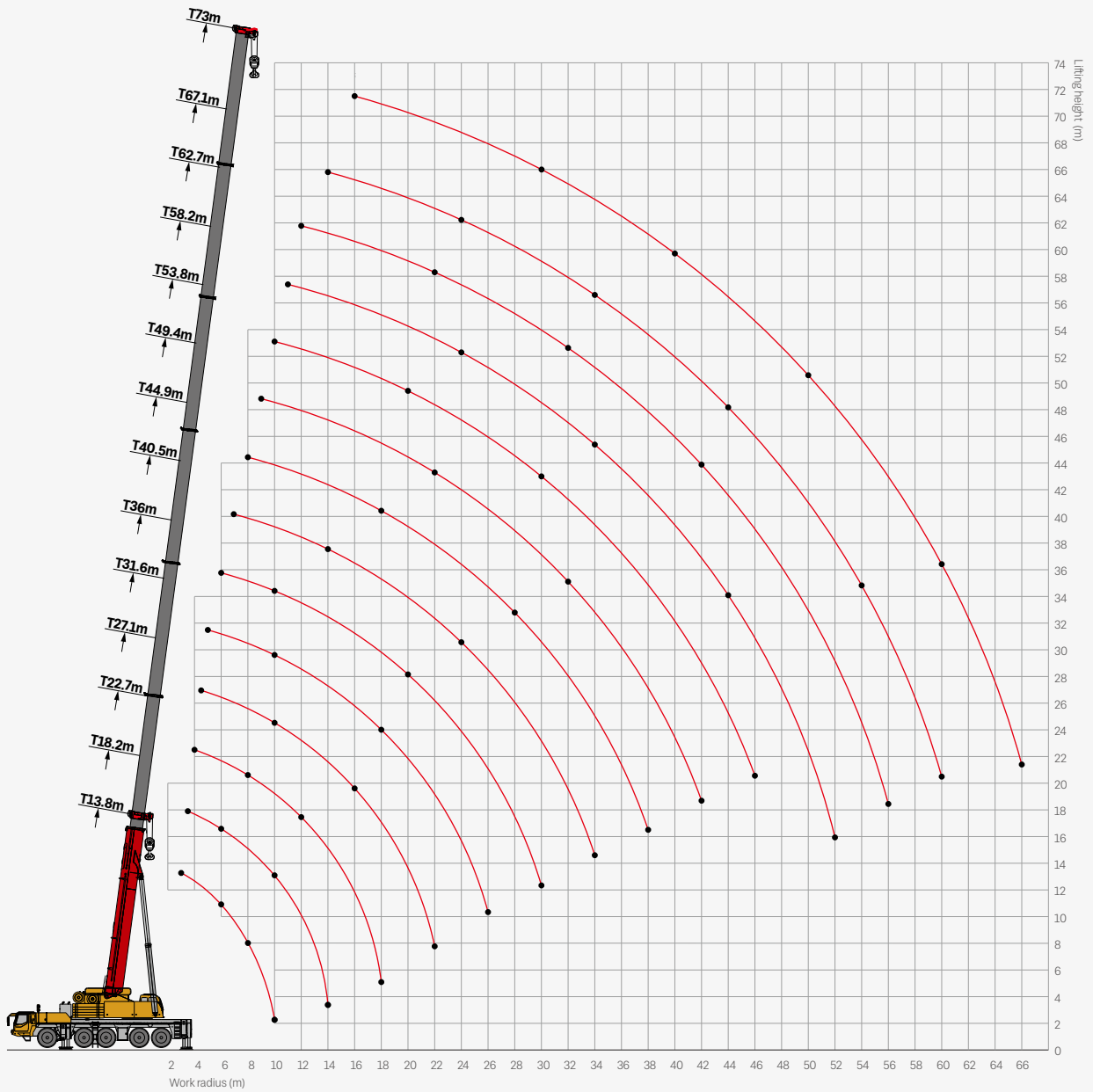

Operating Range - Telescopic Boom

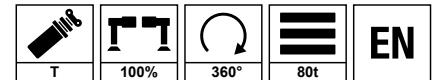

Load Chart-Telescopic Boom



Unit: t

	13.8*	13.8	18.2	22.6	27.2	31.5	36.1	40.4	44.9	49.4	53.8	58.2	62.7	67.1	73	
3	250.0	147.0														3
3.5	160.0	147.0	155.0													3.5
4	150.0	147.0	145.0	140.0												4
4.5		145.0	136.0	132.0	120.0											4.5
5		135.0	128.0	123.0	115.0	110.0										5
6		120.0	113.0	110.0	103.0	101.0										6
7		106.0	102.0	99.0	92.0	95.0	85.0									7
8		94.5	92.5	90.0	83.0	87.0	80.0	65.0								8
9		83.5	83.5	82.0	77.1	79.3	73.5	62.0	51.5							9
10		72.0	76.0	75.0	71.1	73.0	68.0	59.0	47.9	40.9						10
11			71.5	69.0	65.5	67.5	62.0	56.0	44.6	38.7	35.0					11
12			63.0	61.0	57.4	60.0	59.0	53.0	41.8	36.8	32.2	27.7				12
14			50.5	50.0	45.5	48.0	50.0	49.0	37.5	32.8	30.5	26.6	21.0			14
16				41.5	39.0	40.5	42.0	42.0	33.5	29.3	27.5	23.9	20.8	18.1	13.5	16
18				35.5	33.5	34.5	36.0	36.0	29.7	26.5	24.6	21.6	19.3	17.0	13.4	18
20					29.0	30.0	31.0	31.0	25.3	24.2	21.3	19.8	17.6	15.9	13.0	20
22					24.8	26.0	27.5	27.5	24.0	22.0	19.5	18.0	16.2	14.9	12.1	22
24						23.0	24.5	24.5	21.4	20.2	18.0	16.7	15.0	14.0	11.3	24
26						20.5	22.5	21.5	19.6	18.3	16.6	15.4	14.0	13.1	10.7	26
28							20.3	19.5	18.4	16.9	15.3	14.4	13.1	12.3	10.0	28
30							18.5	17.5	16.5	15.6	14.1	13.5	12.1	11.4	9.4	30
32								16.2	15.0	14.4	13.1	12.7	11.3	10.7	8.8	32
34								14.8	14.0	13.3	12.1	11.9	10.6	10.0	8.4	34
36									13.0	12.2	11.3	11.1	10.0	9.3	7.9	36
38									11.8	11.2	10.4	10.6	9.5	8.6	7.5	38
40										10.2	9.8	9.5	9.1	8.1	7.1	40
42										9.2	9.0	8.5	8.5	7.8	6.8	42
44											8.5	7.7	8.1	7.5	6.5	44
46											8.0	7.2	7.3	7.2	6.2	46
48											7.3	6.6	6.6	6.8	5.9	48
50												6.2	6.2	6.0	5.7	50
52												5.8	5.8	5.7	5.3	52
54													5.3	5.0	4.8	54
56													5.0	4.6	4.3	56
58														4.2	3.9	58
60														3.9	3.4	60
62															3.0	62

Remark: Column marked by * indicates load over rear with additional sheaves required.

Operating Range - Fixed Jib

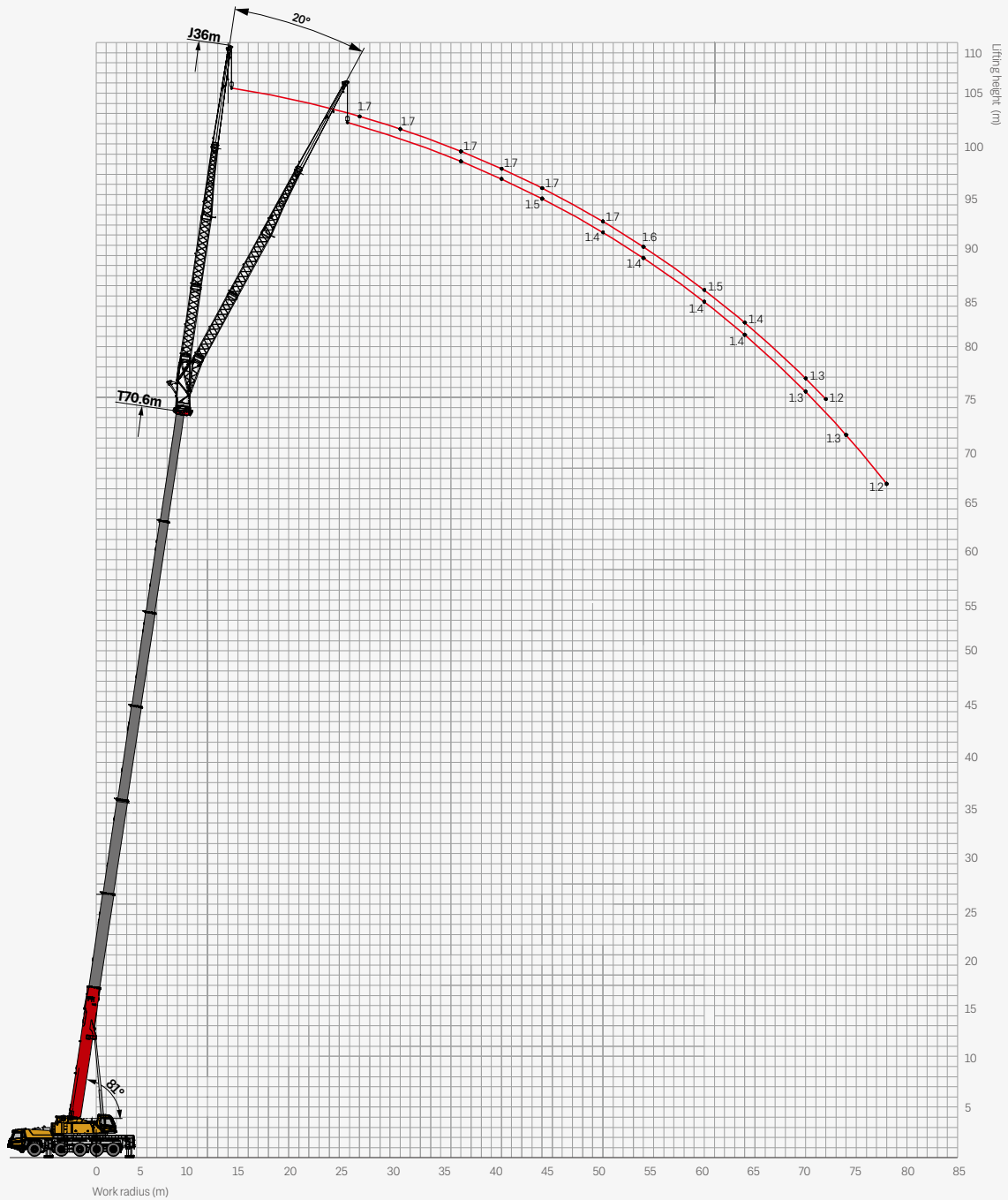

Load Chart - Fixed Jib

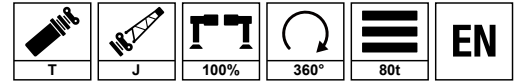

Unit: t

m	53.8+36			58.2+36			62.7+36			67.1+36			73+36		m
	0°	20°	40°	0°	20°	40°	0°	20°	40°	0°	20°	40°	0°	20°	
14	3.7			3.5											14
16	3.7			3.5			3.2								16
18	3.7			3.5			3.2			2.9					18
20	3.7			3.5			3.2			2.9					20
22	3.6			3.4			3.2			2.9			1.7		22
24	3.5			3.3			3.2			2.9			1.7		24
26	3.3			3.2			3.1			2.9			1.7		26
28	3.2	2.5		3.1	2.5		3.0			2.8			1.7		28
30	3.1	2.4		3.0	2.4		2.9	2.4		2.8			1.7		30
32	3.0	2.3		2.9	2.3		2.9	2.3		2.7	2.2		1.7		32
34	2.9	2.2		2.9	2.2		2.8	2.2		2.6	2.1		1.7		34
36	2.9	2.1		2.8	2.2		2.7	2.1		2.5	2.0		1.7		36
38	2.8	2.0	1.5	2.7	2.1	1.5	2.6	2.1	1.5	2.5	2.0		1.7		38
40	2.6	2.0	1.5	2.6	2.0	1.5	2.5	2.0	1.5	2.4	1.9	1.4	1.7		40
42	2.5	1.9	1.5	2.5	2.0	1.5	2.4	1.9	1.5	2.3	1.9	1.4	1.7	1.5	42
44	2.4	1.9	1.5	2.4	1.9	1.5	2.4	1.9	1.5	2.2	1.8	1.4	1.7	1.5	44
46	2.3	1.8	1.4	2.3	1.8	1.4	2.3	1.8	1.4	2.2	1.8	1.4	1.7	1.4	46
48	2.2	1.8	1.4	2.2	1.8	1.4	2.2	1.8	1.4	2.1	1.7	1.4	1.7	1.4	48
50	2.1	1.7	1.4	2.1	1.7	1.4	2.1	1.7	1.4	2.0	1.7	1.4	1.7	1.4	50
52	2.0	1.7	1.4	2.0	1.7	1.4	2.0	1.7	1.4	2.0	1.6	1.4	1.7	1.4	52
54	1.9	1.6	1.4	2.0	1.6	1.4	2.0	1.6	1.4	1.9	1.6	1.4	1.6	1.4	54
56	1.8	1.6	1.4	1.9	1.6	1.4	1.9	1.6	1.4	1.8	1.6	1.4	1.6	1.4	56
58	1.7	1.5	1.4	1.8	1.6	1.4	1.8	1.6	1.4	1.8	1.5	1.4	1.5	1.4	58
60	1.6	1.5	1.4	1.8	1.5	1.4	1.8	1.5	1.4	1.7	1.5	1.4	1.5	1.4	60
62	1.6	1.4	1.4	1.7	1.5	1.4	1.7	1.5	1.4	1.7	1.5	1.4	1.5	1.4	62
64	1.5	1.4	1.4	1.7	1.5	1.4	1.7	1.5	1.4	1.7	1.5	1.4	1.4	1.4	64
66	1.4	1.4	1.4	1.6	1.4	1.4	1.6	1.4	1.4	1.6	1.4	1.4	1.4	1.4	66
68	1.4	1.4	1.4	1.5	1.4	1.4	1.6	1.4	1.4	1.6	1.4	1.4	1.4	1.3	68
70	1.4	1.4	1.4	1.5	1.4	1.4	1.6	1.4	1.4	1.5	1.4	1.4	1.3	1.3	70
72	1.4	1.4		1.4	1.4	1.4	1.5	1.4	1.4	1.5	1.3	1.4	1.2	1.3	72
74	1.4	1.4		1.4	1.4	1.4	1.5	1.4	1.4	1.5	1.3	1.4	1.1	1.3	74
76				1.4	1.4		1.4	1.4	1.4	1.4	1.3	1.4	1.0	1.2	76
78				1.4	1.4		1.4	1.4		1.4	1.3	1.4	0.9	1.2	78
80				1.4			1.3	1.4		1.2	1.3	1.4		1.1	80
82				1.3			1.1	1.3		1.0	1.3			0.9	82
EN	1	1	1	1	1	1	1	1	1	1	1	1	1	1	EN



SANY GROUP CRANE BU

SANY Mobile Crane Industrial Park, No.168 Jinzhou Avenue, Jinzhou Development Zone, Changsha City,
Hunan Province, P.R. China Zip 410600
Consulting sanycrane@sanygroup.com (Crane BU) / crd@sany.com.cn (IHQ)
After-sales Service 0086-400 6098 318

Reminder:

Any change in the technical parameters and configuration due to product modification or upgrade may occur without prior notice.
The machine in the picture may include additional equipment. This brochure is for reference only, and goods in kind shall prevail.
Copyright at SANY. No part of this brochure may be copied or used for any purpose without written approval from SANY.

© Edited in December 2022

