



Telescopic Boom Lift GTBZ-20&22J

Specification

- *Lift capacity : 250KG
- *Width stowed : 2.49m
- *Working height : 22.5m/24.12m

Features

- *Easy to operation, good stability, no impact
- *Telescopic boom and supply more radius
- *Good gradeability, more radius and the whole machine stable

Model GTBZ-22J

Dimension

Working height maximum 24m
 Platform height maximum 22m
 Horizontal height maximum 14m/15.8m
 Length -stowed 10.8m
 Width-stowed 2.49m
 Height-stowed 2.7m
 Platform size(L×W) 2.44m*0.91m
 Wheel base 2.51m
 Ground clearance(center) 0.45m

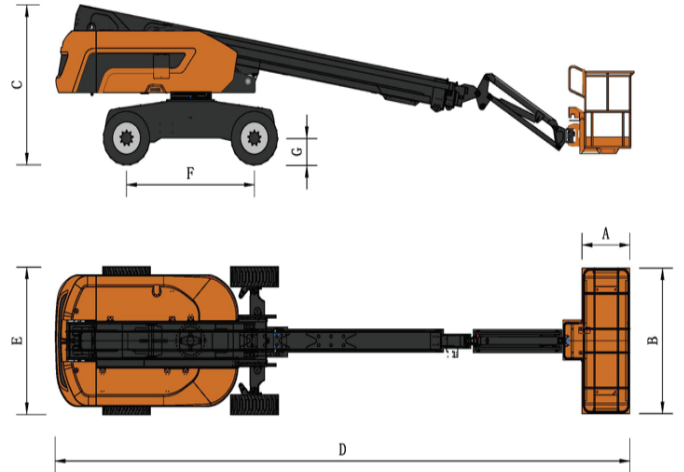

Productivity

Lift capacity 300kg/460kg
 Max platform occupancy 2
 Drive speed-stowed (max) 5.1km/h
 Drive speed-raised (max) 1.1km/h
 Gradeability-stowed 45%
 Turning radius-inside 2.4m
 Turning radius-outside 5.6m
 Turning tail-swing 1.4m
 Working slope maximum 5°
 Tyre 36*14-20

Power

Power source Cummins
 Feul Tank 160L
 Drive & steering 4WD*2WS

Sound level

Sound pressure level(ground workstation)

1.Chassis

- ◇Wide chassis makes the lower part of the Equipment which can bear the load balance to enhance stability.
- ◇355/55D625 Solid Tyre , it can keep stable not only in a variety of complex conditions, but also enhance the ground friction, then the equipment is more stable in operation, and climbing easier.
- ◇The steering system adopts double oil cylinder and Hydra steering system, with 40Cr steering linkage to ensure the same direction.
- ◇Floating leveling device will start automatically when the device encountered under the condition of uneven ground,to ensure the balance of equipment with slope of 6 degrees ,then strengthen the safety and adaptability.

2.Rotation table

- ◇360°continuous rotation,with 50Cr rotary support
- ◇Emergency safety pump. The operator can use emergency safety pump to fall safely,when the equipment is working at high altitude which can not be down.
- ◇Constant pressure pump of Danfoss USA or Rexroth German,it avoid oil leakage caused by gear pump damage in long -term construction
- ◇The electric control system of centralized electric control box is used to ensure the safety of equipment operation
- ◇Ground control console and platform control console, the former has a large screen display, with self diagnostic screen, without connected to the computer,then customers can easily understand the calibration status of equipment and parameters, which is convenient debugging and testing.
- ◇Controller of IFM Germany can enhance system stability
- ◇Turntable safety lock,to avoid the damage in the transport and maintenance of arm rotation
- ◇Swing-out engine bracket - provide the world industry closest to the engine design, easy maintenance and repairs.
- ◇Glass fiber steel cover make the whole equipment nice and durable

3.Boom

- ◇The boom structure adopts 70 high strength steel to ensure the safety of equipment construction
- ◇When the boom is extended, the side boom adopts a sleeve type pipe or line design, which is beautiful and convenient.
- ◇Germany imported IGUS chain, stable performance ,long life and never rust.

4.Platform

- ◇Imported overweight sensor to ensure operator load safely in the construction
- ◇Control system with three joystick to work easily in the multiple compound action
- ◇Foot pedal,handle is effective under pressing foot pedal
- ◇Self lock door to keep safe
- ◇Platform guardrails can rotate around 160 degrees to work conveniently

