



Articulating Boom Lift GTZZ-15J

Specification

- *Lift capacity : 230KG
- *Width stowed : 2.28m
- *Working height : 17m

Features

- *Easy to operation, good stability, no impact
- *Flexible boom, more practical and complex and nurturing work space
- *More power and stronger gradeability.

Technical Parameters

Main feature

Operating range

Model GTZZ-15

Performance

Working height maximum 16.6m
 Platform height maximum 14.6m
 Horizontal height maximum 8.5m
 Up and over clearance max. 7.8m
 Length -stowed[D] 7.7m
 Width-stowed[E] 2.28m
 Height-stowed[C] 2.18m
 Platform size(L×W)[A*B] 1.53*0.76m*1.1m
 Wheel base[F] 2.03m
 Ground clearance[G] 0.25m

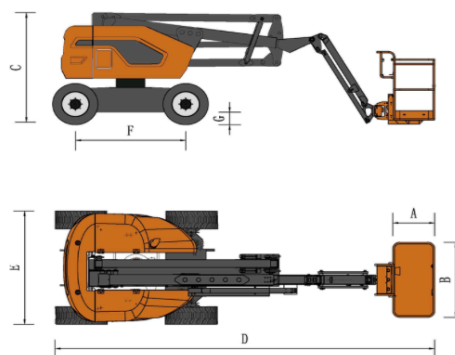

Dimension

230kg
 2
 Lift capacity
 Max platform occupancy 6.8km/h
 Drive speed-stowed(max) 1.1km/h
 Drive speed-raised(max) 40%
 Gradeability-stowed 2.47m
 Turning radius-inside 5.18m
 Turning radius-outside 5°
 Working slope maximum 33*12-20
 Tyre

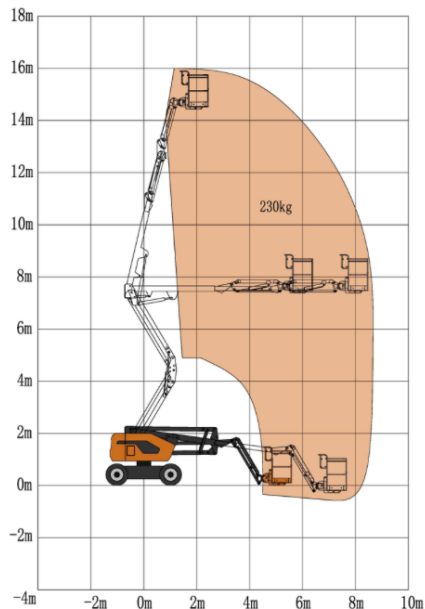

Power

Power source
 Drive & steering YANMAR
 4WD*2WS

Weight

1.Chassis

- ◇Wide chassis makes the lower part of the Equipment which can bear the load balance to enhance stability.
- ◇16/70/20 Solid Tyre, it can keep stable not only in a variety of complex conditions, but also enhance the ground friction, then the equipment is more stable in operation, and climbing easier.
- ◇The steering system adopts double oil cylinder and Hydra steering system, with 40Cr steering linkage to ensure the same direction.
- ◇Floating leveling device will start automatically when the device encountered under the condition of uneven ground,to ensure the balance of equipment with slope of 6 degrees ,then strengthen the safety and adaptability.

2.Rotation table

- ◇360°continuous rotation,with 50Cr rotary support
- ◇Emergency safety pump. The operator can use emergency safety pump to fall safely,when the equipment is working at high altitude which can not be down.
- ◇Constant pressure pump of Danfoss USA or Rexroth German,it avoid oil leakage caused by gear pump damage in long -term construction
- ◇The electric control system of centralized electric control box is used to ensure the safety of equipment operation
- ◇Ground control console and platform control console, the former has a large screen display, with self diagnostic screen, without connected to the computer,then customers can easily understand the calibration status of equipment and parameters, which is convenient debugging and testing.
- ◇Controller of IFM Germany can enhance system stability
- ◇Turntable safety lock,to avoid the damage in the transport and maintenance of arm rotation
- ◇Glass fiber steel cover make the whole equipment nice and durable

3.Boom

- ◇The boom structure adopts 70 high strength steel to ensure the safety of equipment construction
- ◇When the boom is extended, the side boom adopts a sleeve type pipe or line design, which is beautiful and convenient.
- ◇Germany imported IGUS chain, stable performance ,long life and never rust.

4.Platform

- ◇Imported overweight sensor to ensure operator load safely in the construction
- ◇Control system with three joystick to work easily in the multiple compound action
- ◇Foot pedal,handle is effective under pressing foot pedal
- ◇Self lock door to keep safe
- ◇Platform guardrails can rotate around 160 degrees to work conveniently

